

# LELY

HIGH - TECH  
IN AGRICULTURE

ONDERDELENLIJST  
PARTS LIST  
LISTE DE PIECES DE RECHANGE  
ERSATZTEILLISTE

## SPLENDIMO 280 LC

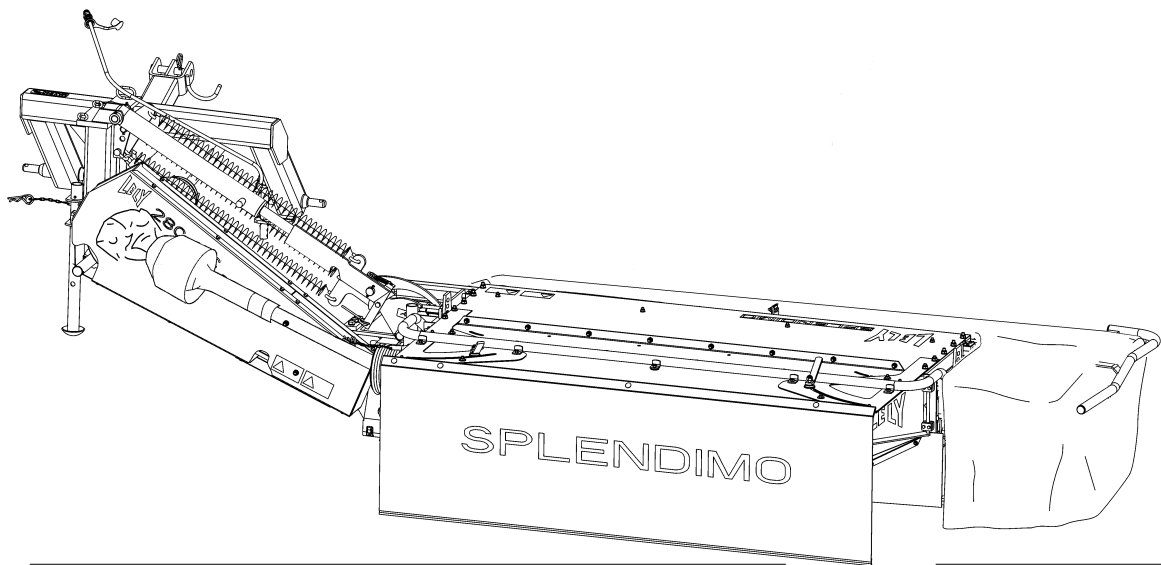

SPLENDIMO	type number type number numéro de type Typennummer	vanaf serienummer as from serial number après numéro serie ab Seriennummer
280 LC	4.1253.0002.1 4.1253.0003.1 4.1253.0004.1	10807 - 0645 3001510 0000000



## ONDERDELEN

Bij het bestellen van onderdelen is het belangrijk dat u het type- en serienummer van uw machine opgeeft. Gebruik alleen originele LELY-onderdelen.

## SPARE PARTS

When ordering spare parts, it is important that you indicate the type and serial number of your machine. Use only genuine LELY parts.

## PIECES DE RECHANGE

En commandant des pièces de rechange il importe que vous indiquez les numéros de type et de série de votre machine. N'utiliser que des pièces d'origines LELY.

## ERSATZTEILE

Beim Bestellen von Ersatzteilen ist es wichtig, daß Sie die Typ- und Seriennummer Ihrer Maschine angeben.

Nur Original-LELY-Ersatzteile verwenden.

Typ- und Seriennummer in nebenstehende Abbildung eintragen. Bei künftigen Bestellungen haben Sie die Nummer dann griffbereit.

Vul het type- en serienummer hieronder in. Bij toekomstige onderdelenbestellingen heeft u de nummers dan bij de hand.

Complete the box below with the type and serial number.

This is an easy reference with a view to future spare parts ordering.

Veillez noter, ci-dessous, les numéros de type et de serie.

Ceci est important pour toutes commandes de pièces de rechange.

<b>LELY</b>	<b>LELY INDUSTRIES NV</b> 3147 PA MAASSLUIS THE NETHERLANDS	<b>CE</b>
	kg	
Type		
Ser.Nr.		

Verklaring van de in de onderdelenlijst gebruikte tekens.  
Explanation of signs used in the parts list.  
Explication des signes qui figurent dans la liste des pièces.  
Erklärung der in der Ersatzteilliste verwendeten Zeichen.

[R]	= RECHTSE UITVOERING RH VERSION	VERSION DROITE RECHTE AUSFÜHRUNG		
[L]	= LINKSE UITVOERING LH VERSION Onder rechtse of linkse uitvoering wordt de plaats van het onderdeel verstaan, gezien van de achterzijde van de machine. By RH or LH version the position of the part is meant, seen from the rear of the machine	VERSION GAUCHE LINKE AUSFÜHRUNG Par version droite ou gauche on entend la position de la pièce, vue de l'arrière de la machine. Die Verweisungen "rechte Ausführung" oder "linke Ausführung" geben die Position des Teils, von der Hinterseite der Maschine aus gesehen, an.		
[RD]	= RECHTSOM DRAAIENDE UITVOERING RH ROTATING VERSION	VERSION ROTATION A DROITE RECHTSUMDREHENDE AUSFÜHRUNG		
[LD]	= LINKSOM DRAAIENDE UITVOERING LH ROTATING VERSION Onder rechtson of linksom draaiende uitvoering wordt de draairichting van het onderdeel verstaan, gezien van de bovenzijde van de machine. By RH or LH rotating version the sense of rotating of the part is meant, seen from the top of the machine.	VERSION ROTATION A GAUCHE LINKSUMDREHENDE AUSFÜHRUNG Version rotation à droit: ceci correspond au sens de rotation de la pièce, vue du dessus la machine. Mit diesen Verweisungen wird die Drehrichtung des Teils von der Oberseite der Maschine aus gesehen, angegeben.		
[x]	= ONDERDEEL WORDT NIET GETOOND PART IS NOT SHOWN Bijvoorbeeld linkse uitvoering overeenkomstig de wel getekende rechtse uitvoering. E.g. : LH version is similar to the RH version, which is actually shown.	PIECE N'EST PAS MONTREE TEIL WIRD NICHT GEZEIGT Exemple : la version gauche est représentée. la version droite correspond à la version gauche, mais n'est pas représentée. Beispiel : die linke Ausführung entspricht der effektiv gezeigten Rechten.		
[#]	= NIET LOS LEVERBAAR NOT AVAILABLE SEPARATELY	VENDU EN KIT UNIQUEMENT NICHT SEPARAT LIEFERBAR		
~	= AANTAL (INDIEN NODIG) AFHANKELIJK VAN INBOUWMAAT QUANTITY (IF APPLICABLE) DEPENDING UPON ASSEMBLY	QUANTITE (SI NÉCESSAIRE) EN FONCTION DU MONTAGE ANZAHL VOM EINBAUMASS ABHÄNGIG (WENN ERFORDERLICH)		
[—]	= SLUITRING	WASHER	RONDELLE PLATE	UNTERLEGSCHEIBE
[—/—]	= VEERRING	SPRING WASHER	RONDELLE GROWER	FEDERRING
[###]	= TANDVEERRING	SHAKE-PROOF WASHER	RONDELLE EVENTAIL	RÄNDELFEEDRING
[> <]	= OLIEKEERRING	OIL SEAL	ETANCHEITE	ÖLDICHTUNGSRING
[T+T]	= TANDWIELSET	PAIR OF GEARS	JEU D'ENGRENAGES	ZAHNRÄDERSATZ
[D+D]	= VULRINGSET	SHIM SET	JEU D'ÉPAISSEURS	PASSSCHEIBENSATZ
[A+A]	= SET AFDICHTINGSRINGEN	SET OF SEALING RINGS	JEU D'ANNEAUX D'ETANCHEITE	DICHTUNGSRINGENSATZ

## SPLENDIMO 280 LC

Inhoud  
Contents  
Index  
Inhalt

pagina  
page  
page  
Seite

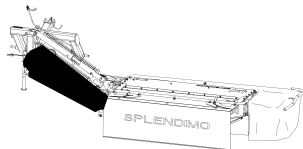

Snaaraandrijving  
V-belt drive  
Entraînement à courroies  
Keilriemenantrieb

01

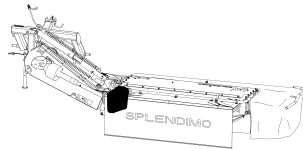

Tandwielkast  
Gearbox  
Boîte d'engrenages  
Getriebe

02-03

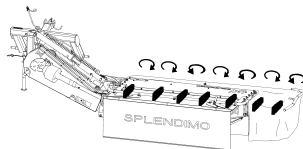

Maaielementen  
Cutting units  
Unités de fauchage  
Mäh-Einheiten

04-05

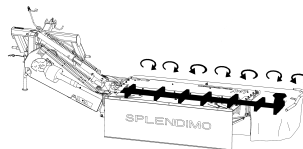

Maaibalk  
Cutter bar  
Barre de coupe  
Mähbalken

06

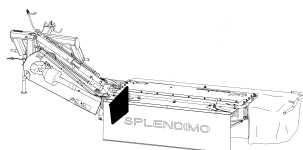

Maaibalkbescherming  
Cutter bar protection  
Protectio-barre  
Mähwerkschutz

07

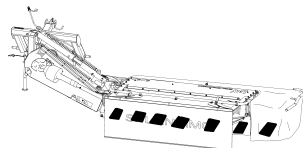

Glijsloten + slijtsloten  
Skids + wear skids  
Patins + patins d'usure  
Kufen + Verschleißkufen

08

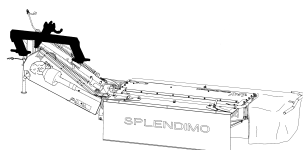

Driepuntsbok  
Headstock  
Tête d'attelage  
Dreipunkturm

09-10

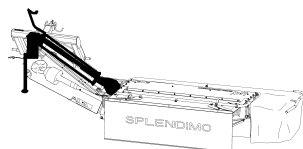

Hydraulische cilinder  
Hydraulic ram  
Vérin hydraulique  
Hydraulikzylinder

11

## SPLENDIMO 280 LC

Inhoud  
Contents  
Index  
Inhalt

pagina  
page  
page  
Seite

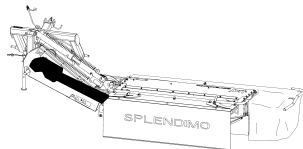

Freem  
Frame  
Châssis  
Rahmen

12

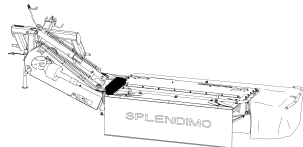

Uitslagbeveiliging  
Anti-shock device  
Dispositif anto choc  
Ausklinkvorrichtung

13

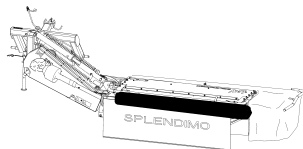

Rotor  
Rotor  
Rotor  
Rotor

14

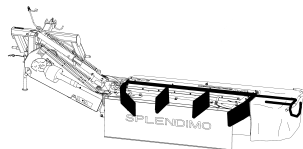

Beveiligingsfreem + zwadbord  
Protection frame + swathboard  
Châssis de protection + planche à andain  
Schutzrahmen + Schwadbrett

15

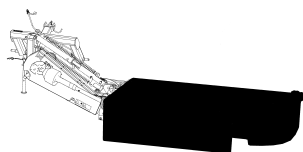

Kneuzerkap  
Conditioner hood  
Capot conditionneuse  
Aufbereiterhaube

16

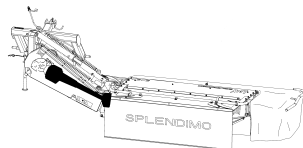

Koppelingsas (rotor)  
PTO shaft (rotor)  
Arbre de transmission (rotor)  
Gelenkwelle (Rotor)

17

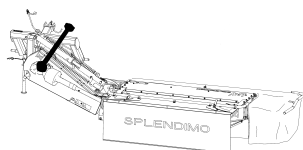

Koppelingsas (trekkerzijde)  
PTO shaft (tractor side)  
Arbre de transmission (côté tracteur)  
Gelenkwelle (Schlepperseite)

18

# LELY

SPLENDIMO	type nummer type number numéro de type Typnummer	vanaf serienummer as from serial number après numéro de serie ab Seriennummer
280 LC	4.1253.0002.1 4.1253.0003.1 4.1253.0004.1	10807 - 0645 3001510 0000000

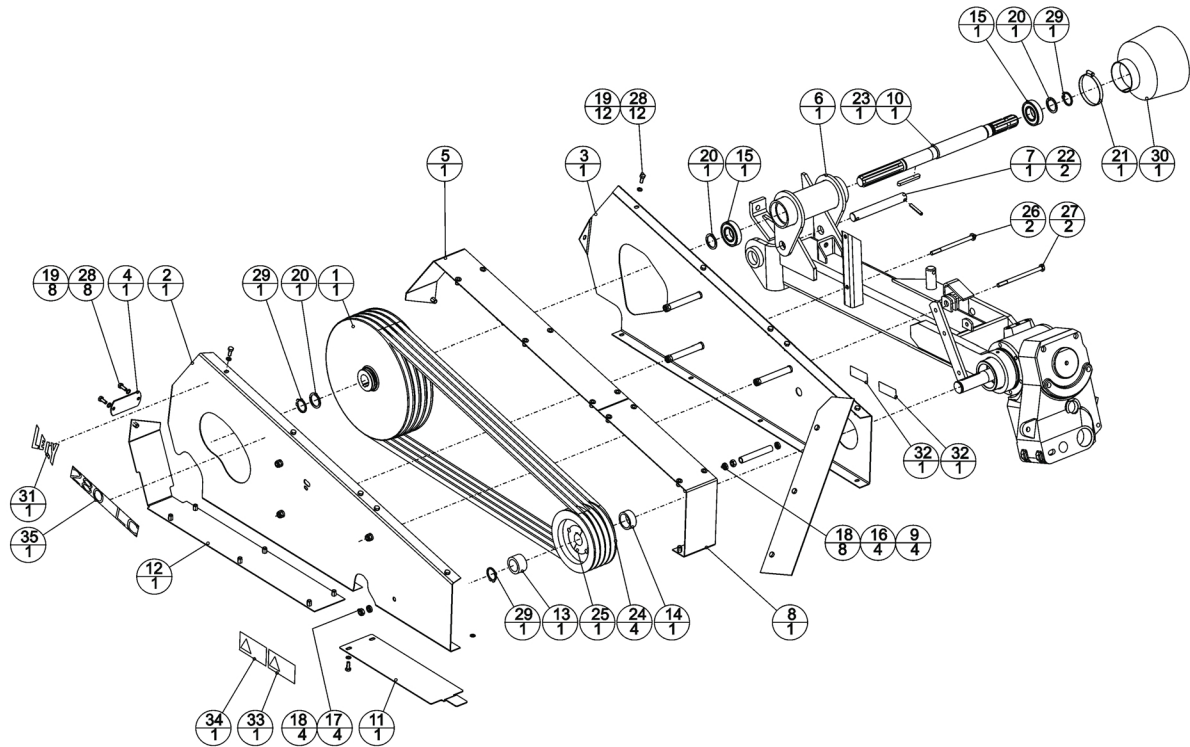
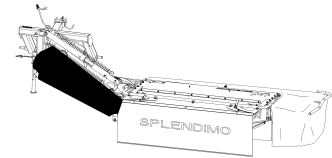

E201-03-00

REF.	ONDERDEELNR. PART NUMBER REFERENCE TEILNUMMER	AANTAL QUANTITY QUANTITE ANZAHL	
1	4-1203-0527-0	1	
2	4-1207-0622-0	1	
3	4-1207-0623-0	1	
4	4-1207-0624-0	1	
5	4-1207-0660-0	1	
6	4-1225-0420-0	1	
7	4-1225-1494-0	1	
8	4-1229-0170-0	1	
9	4-1229-1498-0	4	
10	4-1240-0449-0	1	
11	4-1240-1462-0	1	
12	4-1251-0510-0	1	
13	4-1251-1487-0	1	L= 29mm
14	4-1251-1488-0	1	L= 21mm
15	9-1001-0025-3	2	6207-2RS1
16	9-1029-0005*4	4	M10 DIN 934-8
17	9-1030-0004*2	4	M10 DIN 985-8
18	9-1049-0018-4	12	M10-NYLON
19	9-1051-0001-6	20	A8,2 DIN 6798 [—]
20	9-1052-0006-3	3	S35x45x2,5 DIN 988 [####]
21	9-1066-0010-0	1	Ø70-Ø90
22	9-1070-0023-2	2	Ø8x50 DIN 1481
23	9-1071-0037-1	1	A10x8x80 DIN 6885
24	9-1075-0003-5	4	SPB
25	9-1075-0105-2	1	GY 180 SPB

REF.	ONDERDEELNR. PART NUMBER REFERENCE TEILNUMMER	AANTAL QUANTITY QUANTITE ANZAHL	
26	9-1113-0143*2	2	M10x150 DIN 931-8.8
27	9-1113-0292*4	2	M10x160 DIN 931-8.8
28	9-1113-0341*3	20	M8x20 DIN 933-10.9
29	9-1119-0019-5	3	35x2,5 DIN 471
30	9-1161-0014-0	1	
31	9-1170-0200-2	1	"LELY"
32	9-1170-0205-0	2	"Smeerpunt" "Greasing point" "Point de graissage" "Schmierstelle"
33	9-1170-0407-6	1	
34	9-1170-0420-5	1	
35	9-1170-0451.1	1	"280 LC"

LELY

SPLENDIMO	type number type number numéro de type Typnummer	vanaf serienummer as from serial number après numéro de serie ab Seriennummer
280 LC	4.1253.0002.1 4.1253.0003.1 4.1253.0004.1	10807 - 0645 3001510 0000000

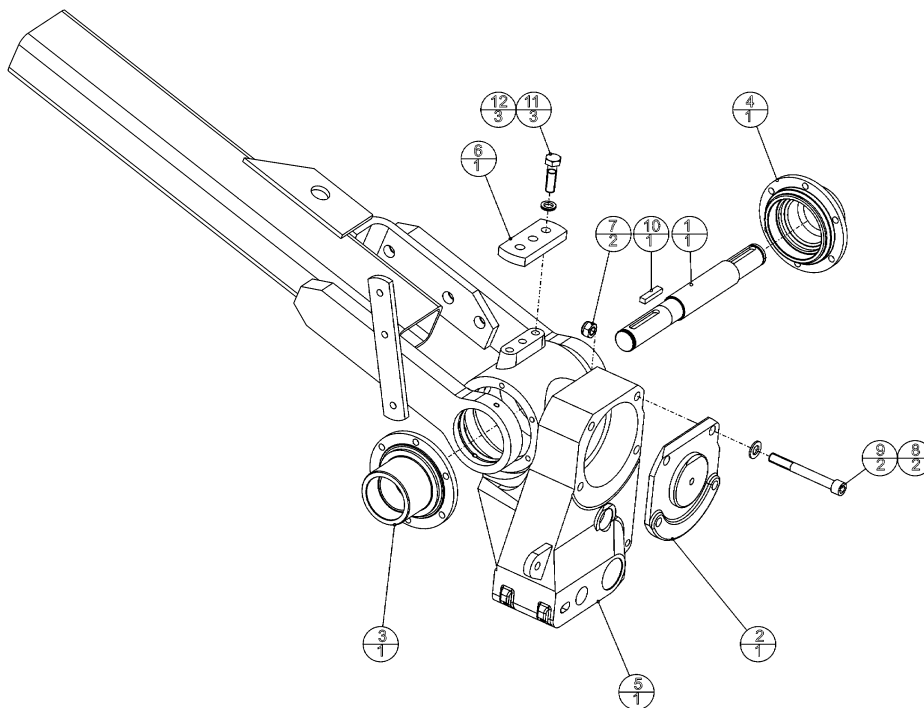
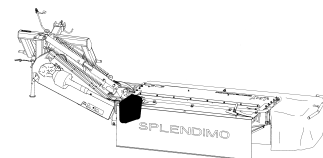

E202-01-00

REF.	ONDERDEELNR. PART NUMBER REFERENCE TEILNUMMER	AANTAL QUANTITY QUANTITE ANZAHL
------	--	--

1	4-1225-0135-0	1	= REF. 17 Pag. 03
2	4-1225-0138-0	1	= REF. 30 Pag. 03
3	4-1225-0139-0	1	= REF. 9 Pag. 03
4	4-1225-0140-0	1	= REF. 11 Pag. 03
5	4-1225-0141-0	1	= REF. 1 Pag. 03
6	4-1251-1490-0	1	
7	9-1030-0015*6	2	M14 DIN 985-8
8	9-1048-0053-5	2	A15 DIN 125
9	9-1057-0083-5	2	M14x120 DIN 912-12.9
10	9-1071-0055-5	1	B10x8x45 DIN 6885
11	9-1113-0359*0	3	M14x50 DIN 931-10.9
12	9-1118-0014-1	3	

REF.	ONDERDEELNR. PART NUMBER REFERENCE TEILNUMMER	AANTAL QUANTITY QUANTITE ANZAHL
------	--	--



SPLENDIMO	type nummer	vanaf serienummer
	type number	as from serial number
	numéro de type	après numéro de serie
	Typnummer	ab Seriennummer
280 LC	4.1253.0002.1 4.1253.0003.1 4.1253.0004.1	10807 - 0645 3001510 0000000

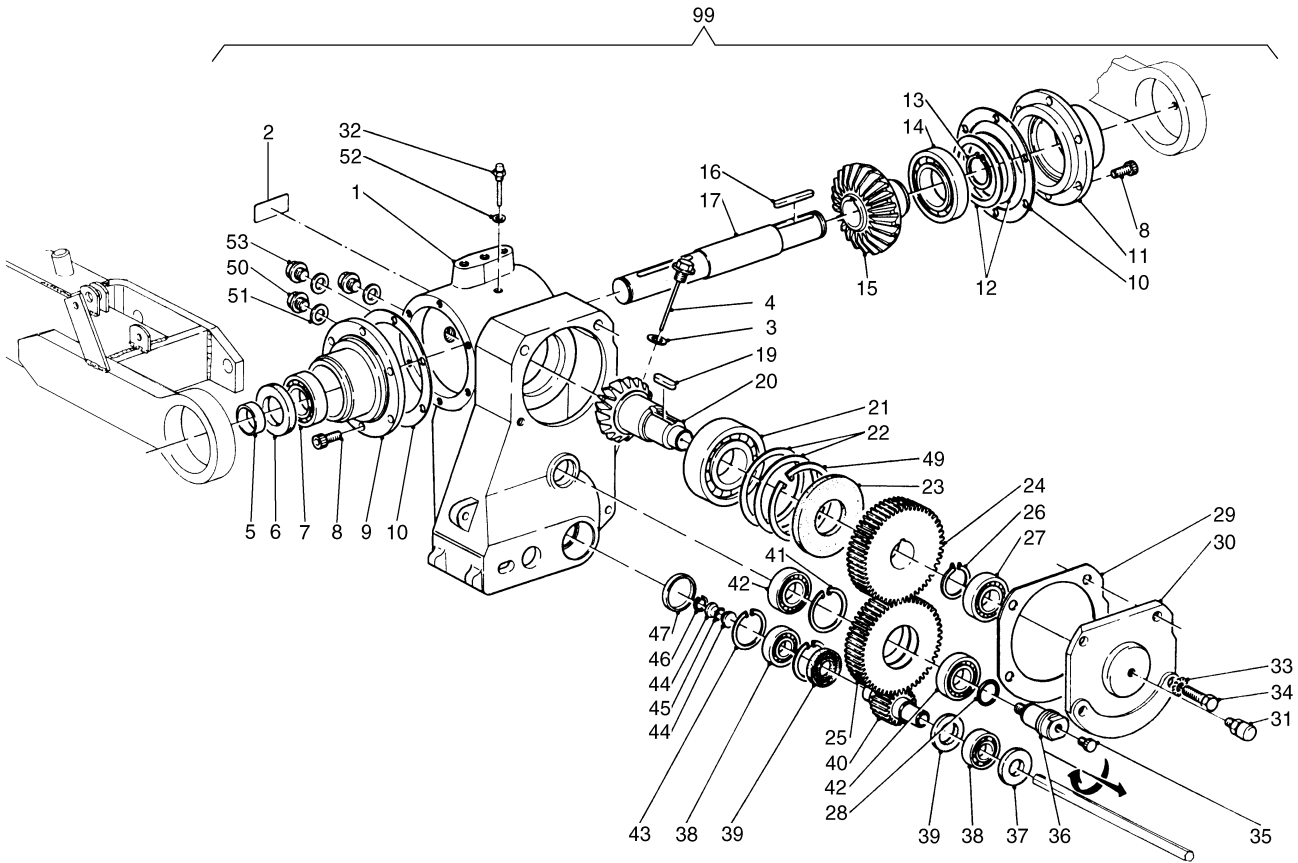
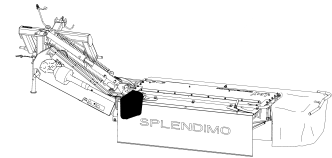

E078-05-10

REF.	ONDERDEELNR. PART NUMBER REFERENCE TEILNUMMER	AANTAL QUANTITY QUANTITE ANZAHL	
1	4.1225.0141.0	1	= REF. 5 Pag. 02
2	9.1170.0352.0	1	"GX85W-140"
3	9.1137.0406.3	1	Ø12,5x19x1,5 Cu [ ]
4	4.1225.0231.0	1	
5	4.1220.0122.0	1	
6	9.1042.0066.3	1	40x72x10 CC NBR [» «]
7	9.1001.0130.3	1	6207 ETN9-C3
8	9.1057.0010.2	12	M10x25 DIN 912-12.9
9	4.1225.0139.0	1	= REF. 3 Pag. 02
10	4.1225.0148.0	2	0,5 mm
11	4.1225.0140.0	1	= REF. 4 Pag. 02
12	4.1225.0142.0	(1)	[D+D] [ ]
13	9.1119.0019.5	1	35x2,50 DIN 471
14	9.1001.0114.1	1	6211 C3
15	4.1225.0151.0	1	
16	9.1071.0021.6	1	A10x8x63 DIN 6885
17	4.1225.0135.0	1	= REF. 1 Pag. 02
19	9.1071.0049.6	1	B12x8x30 DIN 6885
20	4.1225.0137.0	1	
21	9.1001.0127.0	1	6212 C3
22	4.1225.0143.0	(1)	[D+D] [ ]
23	9.1042.0080.3	1	60x110x13 CB [» «]
24	4.1225.0153.0	1	
25	4.1225.0154.0	1	
26	9.1119.0020.6	1	42x1,75 DIN 471
27	9.1001.0107.1	1	6207 C3
28	9.1043.0044.1	1	OR Ø29,2x3,0

REF.	ONDERDEELNR. PART NUMBER REFERENCE TEILNUMMER	AANTAL QUANTITY QUANTITE ANZAHL	
29	4.1225.0145.0	1	
30	4.1225.0138.0	1	= REF. 2 Pag. 02
31	9.1150.0011.1	1	G1/4" SLW 17
32	9.1150.0015.5	1	G1/4" SLW 14-L= 45 mm
33	9.1051.0005*3	2	A14,5 DIN 6798 [####]
34	9.1113.0142*1	2	M14x40 DIN 933-8.8
35	9.1108.0034.3	1	G1/8"
36	4.1225.0136.0	1	M14-L
37	9.1042.0074.4	1	25x52x7 CB [» «]
38	9.1001.0129.2	2	6205 C5
39	9.1042.0075.5	2	30x52x7 CB [» «]
40	4.1225.0155.0	1	
41	9.1120.0005.4	1	62x2,00 DIN 472
42	9.1001.0063.6	2	6305 C4
43	9.1120.0003.2	2	52x2,00 DIN 472
44	4.1225.0144.0	2	
45	9.1043.0045.2	1	OR 14x2,0
46	9.1120.0028.6	1	18x1,00 DIN 472
47	9.1108.0079.0	1	Ø52x6,5
49	9.1120.0016.1	1	110x4,00 DIN 472
50	9.1131.0013.1	2	R1/2" DIN 910 PM-5.8
51	9.1137.0411.1	3	NBR-2C 21,54x28,58x2,34
52	9.1137.0401.5	1	Ø14x20x1,5 Cu [ ]
53	9.1131.0012.0	1	R1/2" DIN 910-5.8
99	4.1225.0111.2	1	= REF. 1-53

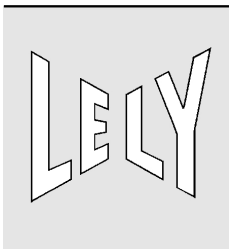

SPLENDIMO	type nummer type number numéro de type Typnummer	vanaf serienummer as from serial number après numéro de serie ab Seriennummer
	280 LC	4.1253.0002.1 4.1253.0003.1 4.1253.0004.1
		10807 - 0645 3001510 0000000

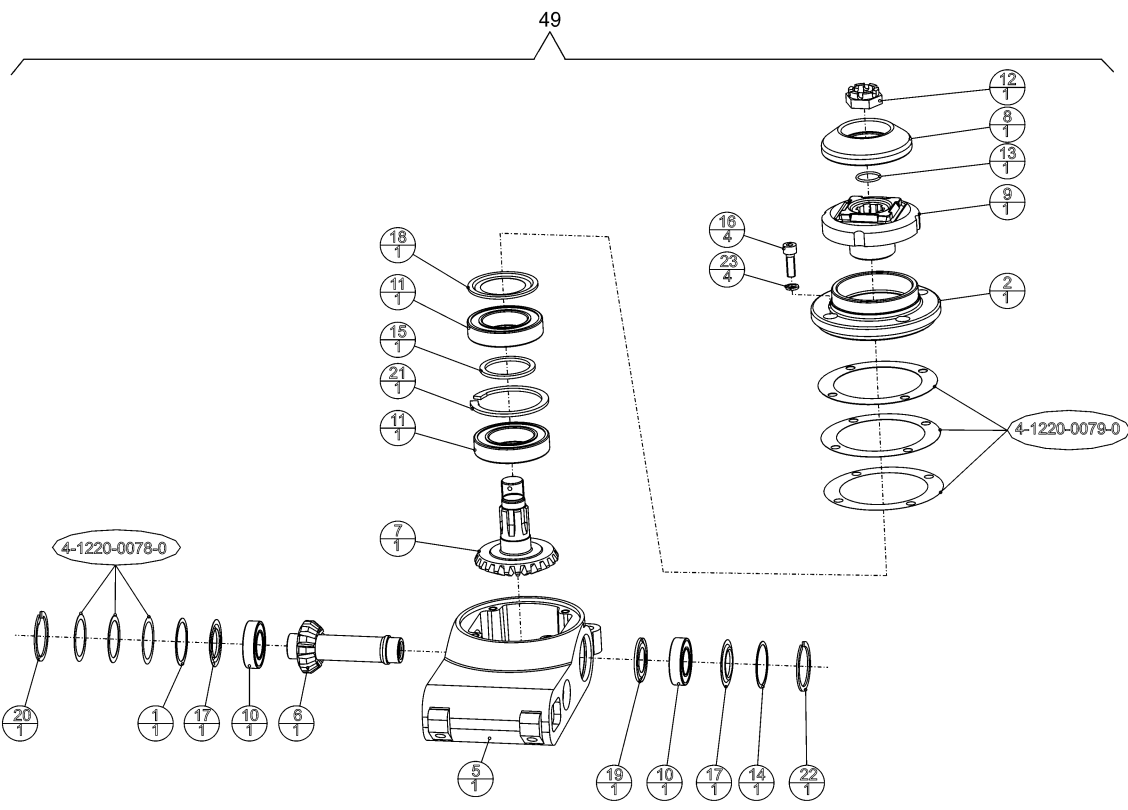
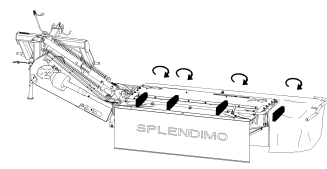

E203-01-00

REF.	ONDERDEELNR. PART NUMBER REFERENCE TEILNUMMER	AANTAL QUANTITY QUANTITE ANZAHL
------	--	--

1	4-1201-0061-0	1
2	4-1220-0061-0	1
3	4-1220-0078-0	~ [D+D] [—]
4	4-1220-0079-0	~ [D+D] [—]
5	4-1220-0287-0	1
6	4-1220-0288-0	1
7	4-1220-0289-0	1
8	4-1220-1467-0	1
9	4-1225-0189-0	1
10	9-1001-0064-0	2 6005-2RS1-C4
11	9-1001-0065-1	2 6009-2RS1-C5L
12	9-1031-0014-4	1 M22x1,5 DIN 937-22H
13	9-1043-0061-4	1 Ø23x2
14	9-1049-0013-6	1 46,5x40-G6005
15	9-1052-0004-1	1 S45x55x3 DIN 988
16	9-1057-0089-4	4 M8x25 DIN 912-12.9
17	9-1107-0007-5	2 6005 ZJV
18	9-1107-0008-6	1 6009 ZAV
19	9-1107-0014-5	1 6005 ZAV -0.1/-0.2
20	9-1120-0002-1	1 47x1,75 DIN 472
21	9-1120-0026-4	1 75x3,00 DIN 472
22	9-1120-0027-5	1 47x1,75 V
23	9-1121-0024-1	4 8 DIN 7980 [—]

REF.	ONDERDEELNR. PART NUMBER REFERENCE TEILNUMMER	AANTAL QUANTITY QUANTITE ANZAHL
------	--	--

49	4.1220.0270.1	4 = REF. 1-23 [RD]
----	---------------	--------------------





SPLENDIMO	type nummer type number numéro de type Typnummer	vanaf serienummer as from serial number après numéro de serie ab Seriennummer
	280 LC	4.1253.0002.1 4.1253.0003.1 4.1253.0004.1
		10807 - 0645 3001510 0000000

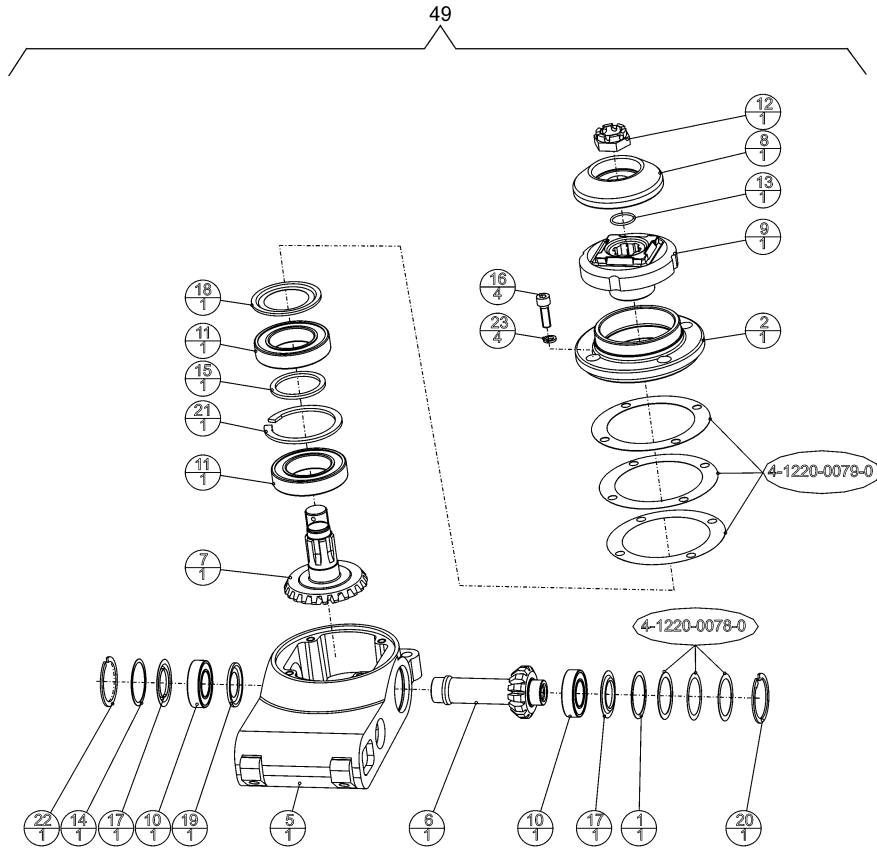
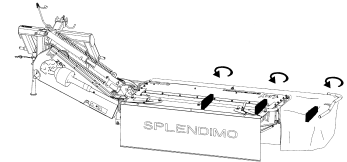

E204-01-00

REF.	ONDERDEELNR. PART NUMBER REFERENCE TEILNUMMER	AANTAL QUANTITY QUANTITE ANZAHL
------	--	--

1	4-1201-0061-0	1
2	4-1220-0061-0	1
3	4-1220-0078-0	~ [D+D] [—]
4	4-1220-0079-0	~ [D+D] [—]
5	4-1220-0287-0	1
6	4-1220-0288-0	1
7	4-1220-0289-0	1
8	4-1220-1467-0	1
9	4-1225-0189-0	1
10	9-1001-0064-0	2 6005-2RS1-C4
11	9-1001-0065-1	2 6009-2RS1-C5L
12	9-1031-0014-4	1 M22x1,5 DIN 937-22H
13	9-1043-0061-4	1 Ø23x2
14	9-1049-0013-6	1 46,5x40-G6005
15	9-1052-0004-1	1 S45x55x3 DIN 988
16	9-1057-0089-4	4 M8x25 DIN 912-12.9
17	9-1107-0007-5	2 6005 ZJV
18	9-1107-0008-6	1 6009 ZAV
19	9-1107-0014-5	1 6005 ZAV -0.1/-0.2
20	9-1120-0002-1	1 47x1,75 DIN 472
21	9-1120-0026-4	1 75x3,00 DIN 472
22	9-1120-0027-5	1 47 X 1,75 V
23	9-1121-0024-1	4 8 DIN 7980 [—]

REF.	ONDERDEELNR. PART NUMBER REFERENCE TEILNUMMER	AANTAL QUANTITY QUANTITE ANZAHL
------	--	--

49	4.1220.0290.1	3 = REF. 1-23 [LD]
----	---------------	--------------------

# LELY

SPLENDIMO	type number type number numéro de type Typnummer	vanaf serienummer as from serial number après numéro de serie ab Seriennummer
280 LC	4.1253.0002.1 4.1253.0003.1 4.1253.0004.1	10807 - 0645 3001510 00000 - 0000

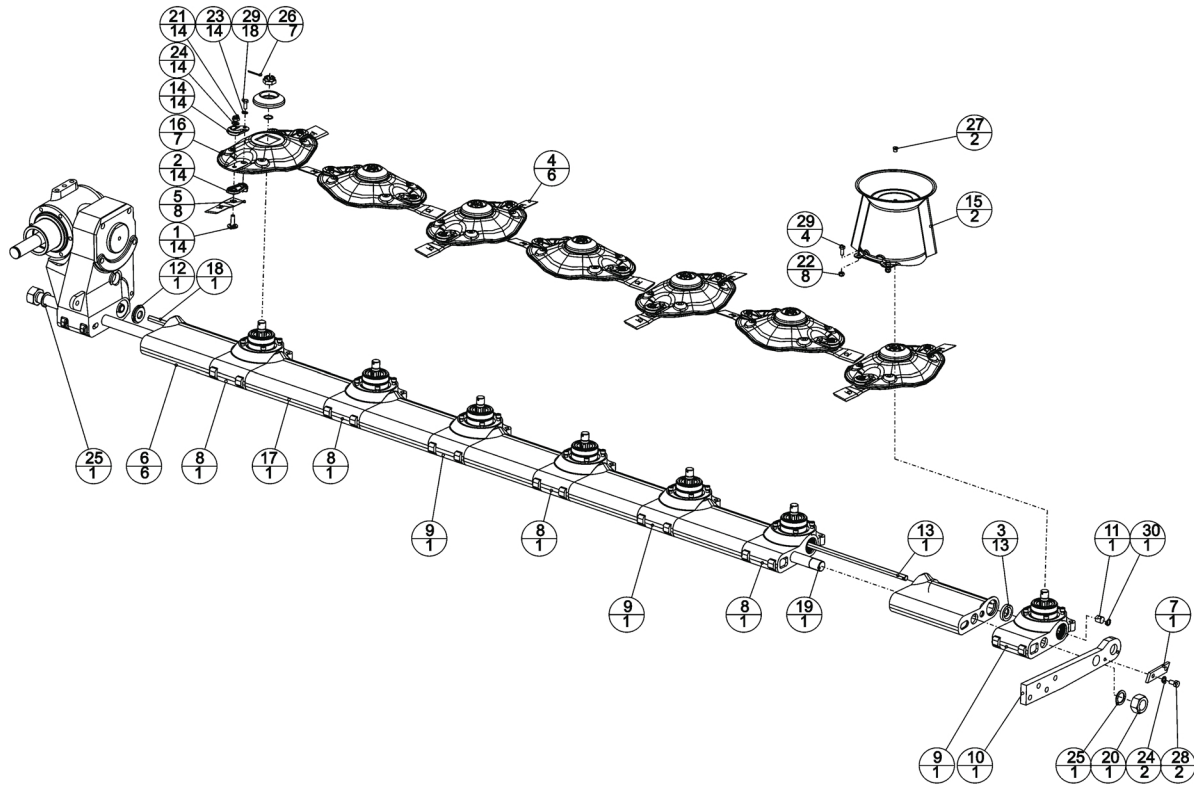
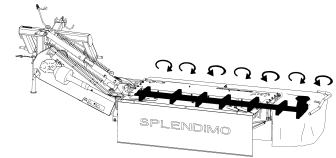

E205-03-00

REF.	ONDERDEELNR. PART NUMBER REFERENCE TEILNUMMER	AANTAL QUANTITY QUANTITE ANZAHL
------	--	--

1	4-1201-0141-0	14
2	4-1201-0142-0	14
3	4-1201-0145-0	13
4	4-1201-1473-0	6
5	4-1201-1474-0	8
		L= 120 mm [LD]
		L= 120 mm [RD]
6	4-1220-0033-0	6
7	4-1220-0034-0	1
8	4-1220-0270-1	4
		= REF. 49 Pag. 04
9	4-1220-0290-1	3
		= REF. 49 Pag. 05
10	4-1220-1330-0	1
11	4-1225-0108-0	1
12	4-1225-0109-0	1
13	4-1225-0179-0	1
		1547 mm
14	4-1225-0449-0	14
15	4-1225-0480-0	2
16	4-1225-1489-0	7
17	4-1229-0109-A	1
18	4-1229-0148-0	1
		1203 mm
19	4-1242-0120-0	1
20	9-1029-0024-2	1
		M30x1,5 DIN 934-10
21	9-1030-0018*2	14
		M10 DIN 985-10
22	9-1030-0040*3	8
		M8 DIN 985-10
23	9-1051-0001-6	14
		A8,2 DIN 6798 [####]
24	9-1051-0002-0	16
		A10,5 DIN 6798 [####]
25	9-1052-0011-1	2
		S30x42x2,5 DIN 988

REF.	ONDERDEELNR. PART NUMBER REFERENCE TEILNUMMER	AANTAL QUANTITY QUANTITE ANZAHL
------	--	--

26	9-1072-0030-0	7
		3,2x36 DIN 94
27	9-1108-0063-5	2
		Ø9,3
28	9-1113-0027*5	2
		M10x20 DIN 933-8.8
29	9-1113-0341*3	22
		M8x20 DIN 933-10.9
30	9-1120-0028-6	1
		18x1,00 DIN 472

# LELY

SPLENDIMO	type number type number numéro de type Typnummer	vanaf serienummer as from serial number après numéro de serie ab Seriennummer
280 LC	4.1253.0002.1 4.1253.0003.1 4.1253.0004.1	10807 - 0645 3001510 0000000

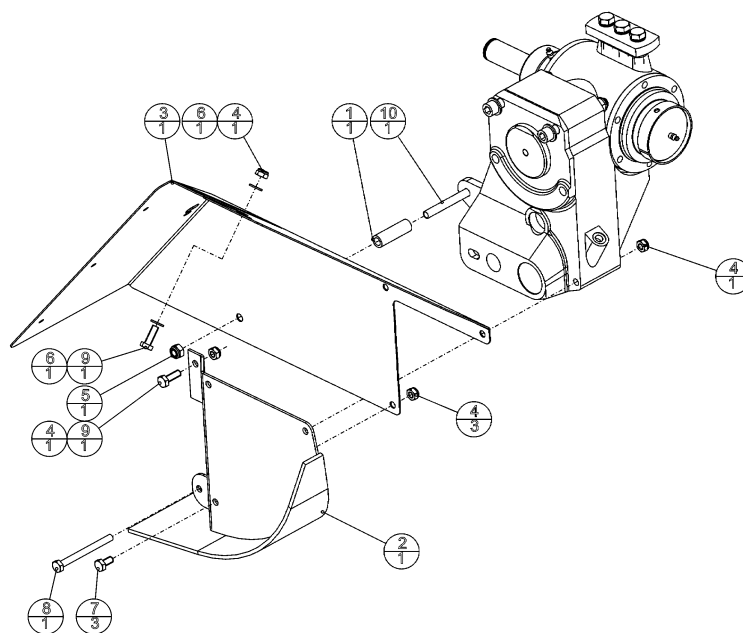
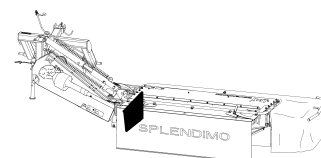

E206-01-00

REF.	ONDERDEELNR. PART NUMBER REFERENCE TEILNUMMER	AANTAL QUANTITY QUANTITE ANZAHL
------	--	--

1	2-1003-0896-0	1
2	4-1225-0251-0	1
3	4-1240-1482-0	1
4	9-1030-0004*2	6
5	9-1030-0013*4	1
6	9-1048-0007-1	2
7	9-1113-0027*5	3
8	9-1113-0043*0	1
9	9-1113-0120*0	2
10	9-1113-0136*2	1

REF.	ONDERDEELNR. PART NUMBER REFERENCE TEILNUMMER	AANTAL QUANTITY QUANTITE ANZAHL
------	--	--

M10 DIN 985-8  
M12 DIN 985-8

A10,5 DIN 125 [—]  
M10x20 DIN 933-8.8  
M10x110 DIN 931-8.8  
M10x30 DIN 933-8.8  
M12x100 DIN 931-8.8



SPLENDIMO	type nummer type number numéro de type Typnummer	vanaf serienummer as from serial number après numéro de serie ab Seriennummer
	280 LC	4.1253.0002.1 4.1253.0003.1 4.1253.0004.1
		10807 - 0645 3001510 0000000

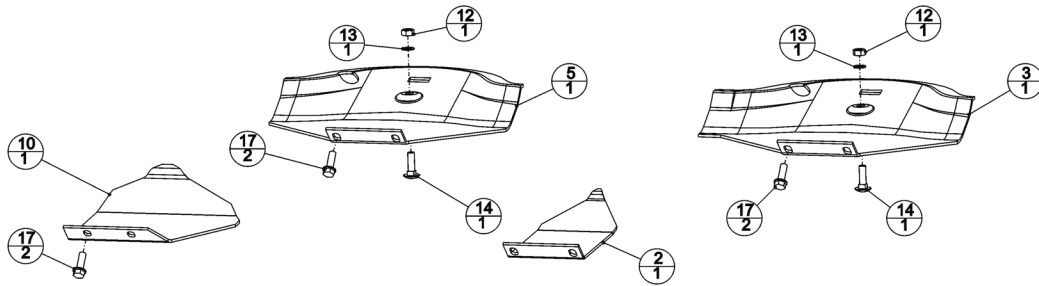
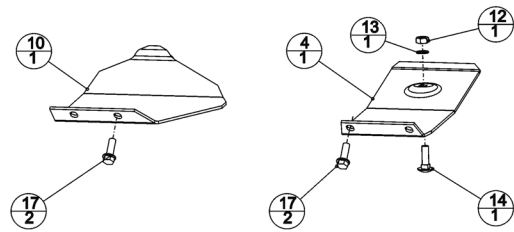
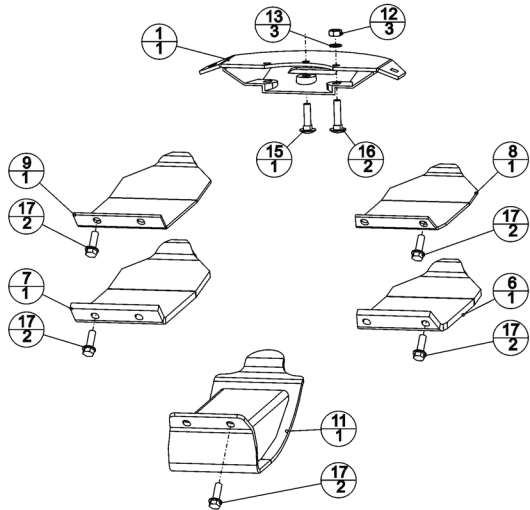
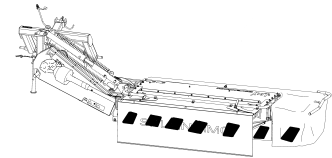

E221-01-00

REF.	ONDERDEELNR. PART NUMBER REFERENCE TEILNUMMER	AANTAL QUANTITY QUANTITE ANZAHL
------	--	--

1	4-1220-0341-0	1
2	4-1220-1320-0	1
	4mm	
	Slijtplaat Wearplate Plaque d'usure Verschleissplatte	
3	4-1220-1961-0	1
4	4-1220-1962-0	1
5	4-1220-1963-0	1
6	4-1225-0359-0	1
	10mm	
	Slijtplaat Wearplate Plaque d'usure Verschleissplatte	
7	4-1225-0369-0	1
	10mm	
	Slijtplaat Wearplate Plaque d'usure Verschleissplatte	
8	4-1225-0499-0	1
	4mm	
	Slijtplaat Wearplate Plaque d'usure Verschleissplatte	
9	4-1225-0509-0	1
	4mm	
	Slijtplaat Wearplate Plaque d'usure Verschleissplatte	

REF.	ONDERDEELNR. PART NUMBER REFERENCE TEILNUMMER	AANTAL QUANTITY QUANTITE ANZAHL
------	--	--

10	4-1225-0569-0	2
	4mm	
	Slijtplaten Wearplates Plaques d'usure Verschleissplatten	
11	4-1225-0670-0	1
12	9-1029-0005-4	6
13	9-1051-0002-0	6
14	9-1058-0015*6	3
15	9-1058-0048*4	1
16	9-1058-0049*5	2
17	9-1114-0009-0	20
	M10x30 8.8	

LELY

SPLENDIMO	type number type number numéro de type Typnummer	vanaf serienummer as from serial number après numéro de serie ab Seriennummer
280 LC	4.1253.0002.1 4.1253.0003.1 4.1253.0004.1	10807 - 0645 3001510 0000000

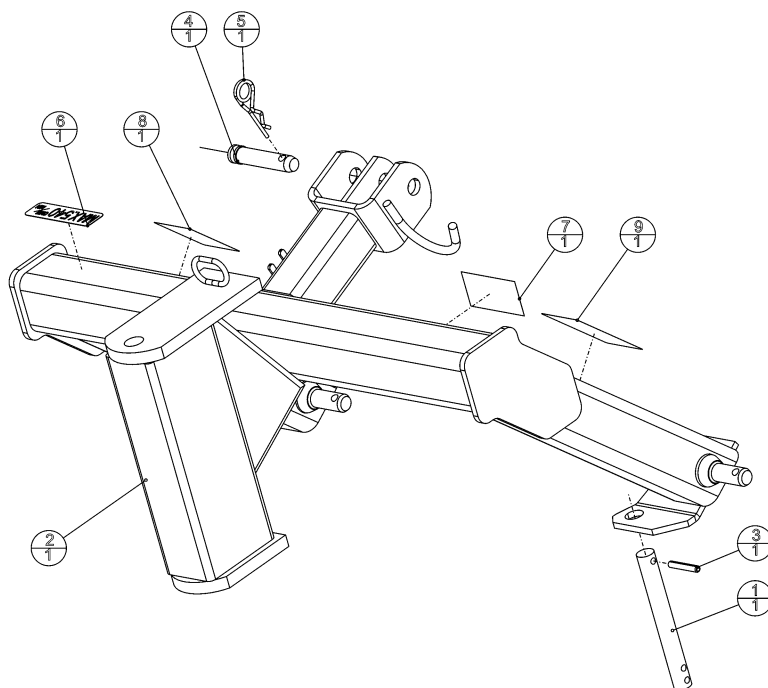
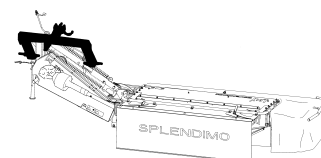

E208-01-00

REF.	ONDERDEELNR. PART NUMBER REFERENCE TEILNUMMER	AANTAL QUANTITY QUANTITE ANZAHL
------	--	--

1	4-1220-1466-0	1
2	4-1220-1710-0	1
3	9-1070-0028-0	1
4	9-1088-0005-1	1
5	9-1124-0004*6	1
6	9-1170-0125-4	1
7	9-1170-0408-0	1
8	9-1170-0431-2	1
9	9-1170-0573-4	1

REF.	ONDERDEELNR. PART NUMBER REFERENCE TEILNUMMER	AANTAL QUANTITY QUANTITE ANZAHL
------	--	--

	Ø10x60 DIN 1481	
	25-95	
	Ø5	
	"MAX 540/min"	

LELY

SPLENDIMO	type nummer type number numéro de type Typnummer	vanaf serienummer as from serial number après numéro de série ab Seriennummer
280 LC	4.1253.0002.1 4.1253.0003.1 4.1253.0004.1	10807 - 0645 3001510 0000000

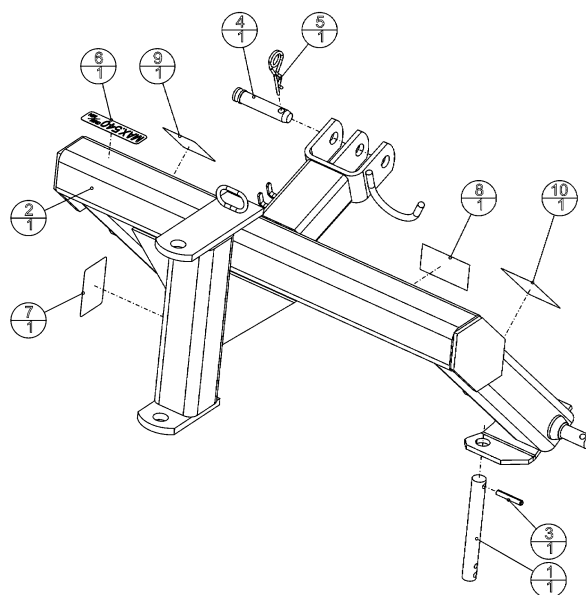
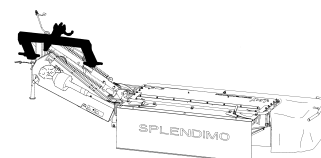

E209-01-00

REF.	ONDERDEELNR. PART NUMBER REFERENCE TEILNUMMER	AANTAL QUANTITY QUANTITE ANZAHL
------	--	--

1	4-1220-1466-0	1
2	4-1242-0370-0	1
3	9-1070-0028-0	1
4	9-1088-0005-1	1
5	9-1124-0004*6	1
6	9-1170-0125-4	1
7	9-1170-0281-6	1
	"Maaihoogte	22" 55 cm"
	"Mowing height	22" 55 cm"
	"Hautr. de fauchage	22" 55 cm"
	"Mähhöhe	22" 55 cm"
8	9-1170-0408-0	1
9	9-1170-0431-2	1
10	9-1170-0573-4	1

REF.	ONDERDEELNR. PART NUMBER REFERENCE TEILNUMMER	AANTAL QUANTITY QUANTITE ANZAHL
------	--	--

# LELY

SPLENDIMO	type number type number numéro de type Typnummer	vanaf serienummer as from serial number après numéro de serie ab Seriennummer
280 LC	4.1253.0002.1 4.1253.0003.1 4.1253.0004.1	10807 - 0645 3001510 0000000

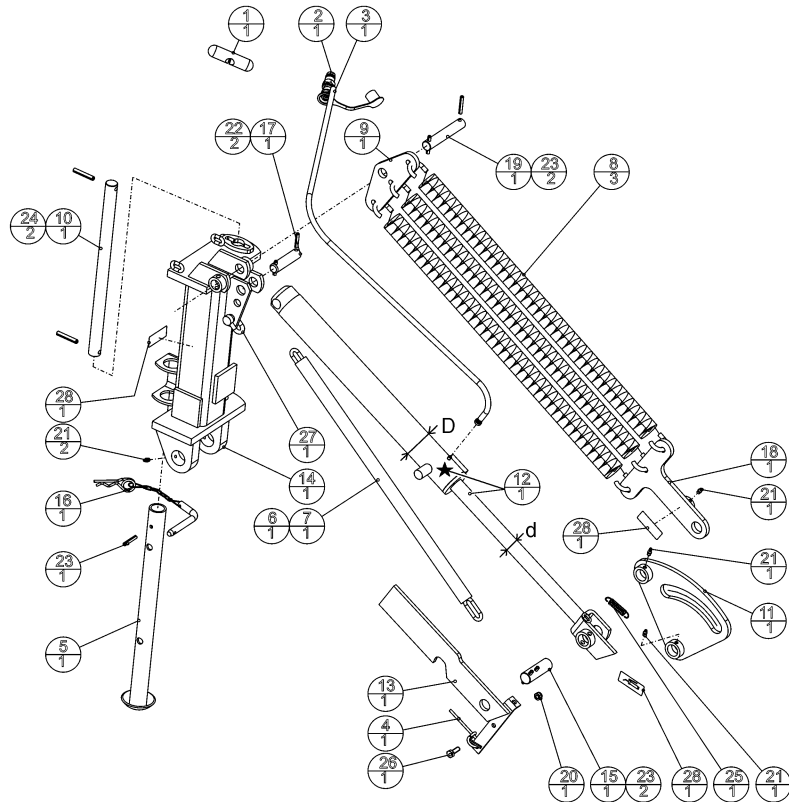
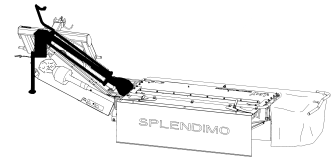

E210-01-01

REF.	ONDERDEELNR. PART NUMBER REFERENCE TEILNUMMER	AANTAL QUANTITY QUANTITE ANZAHL	
1	2-3201-0328-0	1	
2	2-3201-2312-0	1	1/4"
3	4-1016-0530-0	1	
4	4-1201-1462-0	1	
5	4-1207-0250-0	1	
6	4-1207-0609-0	1	
7	4-1207-0615-0	1	
8	4-1207-0616-0	3	
9	4-1207-0638-0	1	
10	4-1240-0229-0	1	
11	4-1240-0382-0	1	
12	4-1240-0401-0	1	(12= 12+ *)
*	4.1207.0399.0	(1)	(d= Ø35, D= Ø60/70) [A+A][x]
13	4-1240-0410-0	1	
14	4-1240-0420-0	1	
15	4-1240-1463-0	1	
16	4-1241-1020-0	1	
17	4-1241-1962-0	1	
18	4-1251-0290-0	1	
19	4-1251-1485-0	1	
20	9-1030-0004*2	1	M10 DIN 985-8
21	9-1068-0007*2	5	AM8x1,25
22	9-1070-0021-0	2	Ø8x40 DIN 1481

REF.	ONDERDEELNR. PART NUMBER REFERENCE TEILNUMMER	AANTAL QUANTITY QUANTITE ANZAHL	
23	9-1070-0023-2	5	Ø8x50 DIN 1481
24	9-1070-0028-0	2	Ø10x60 DIN 1481
25	9-1089-0014-2	1	
26	9-1113-0120*0	1	M10x30 DIN 933-8.8
27	9-1146-0006-0	1	
28	9-1170-0205-0	3	"Smeerpunt" "Greasing point" "Point de graissage" "Schmierstelle"

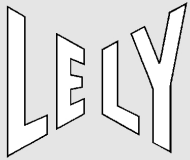

SPLENDIMO	type nummer	vanaf serienummer
	type number	as from serial number
	numéro de type	après numéro de serie
	Typnummer	ab Seriennummer
280 LC	4.1253.0002.1 4.1253.0003.1 4.1253.0004.1	10807 - 0645 3001510 0000000

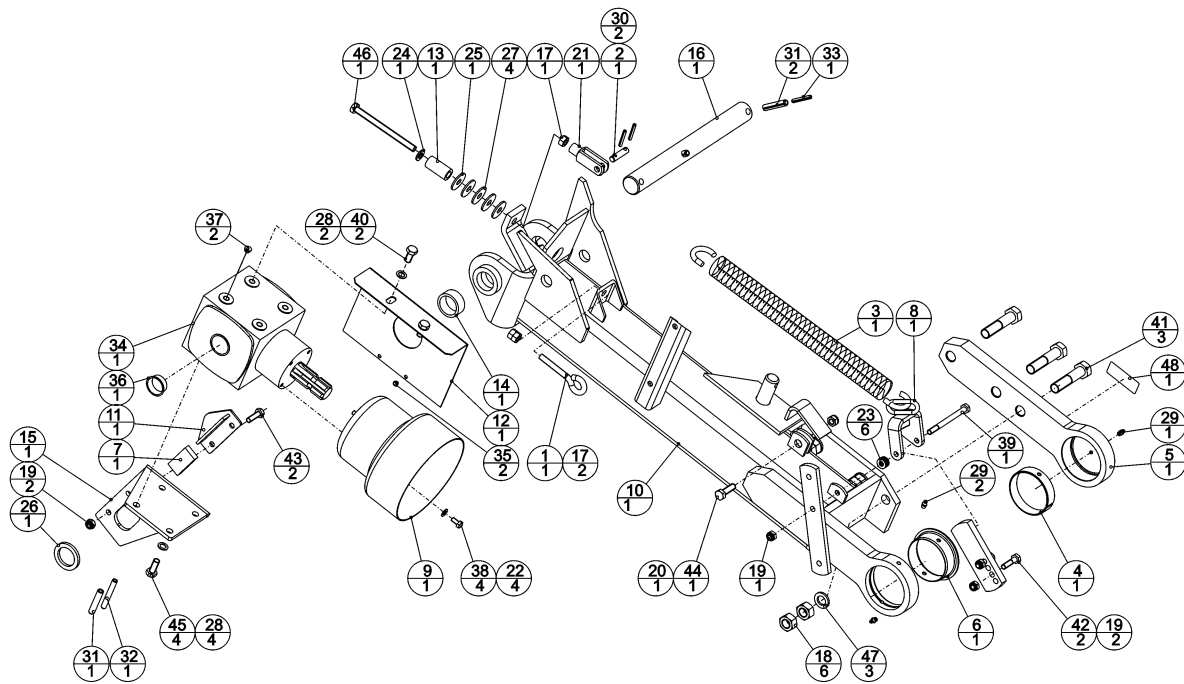
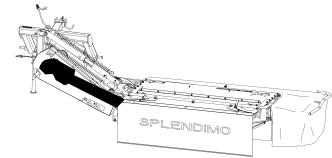

E211-03-00

REF.	ONDERDEELNR. PART NUMBER REFERENCE TEILNUMMER	AANTAL QUANTITY QUANTITE ANZAHL
------	--	--

1	1-1633-1495-0	1
2	4-1201-1471-0	1
3	4-1201-1481-A	1
4	4-1201-1482-0	1
5	4-1207-0580-0	1
6	4-1207-0620-0	1
7	4-1207-1494-0	1
8	4-1233-0170-0	1
9	4-1240-1479-0	1
10	4-1242-0380-0	1
11	4-1251-0340-0	1
12	4-1251-1479-0	1
13	4-1251-1483-0	1
14	4-1251-1488-0	1
15	4-1251-1489-0	1
16	4-1253-1495-0	1
17	9-1029-0008*0	3 M12 DIN 934-8
18	9-1029-0016*1	6 M20 DIN 934-8
19	9-1030-0004*2	5 M10 DIN 985-8
20	9-1030-0013*4	1 M12 DIN 985-8
21	9-1038-0006-3	1 M12x48 DIN 71752
22	9-1048-0004-5	4 A8,4 DIN 125 [—]
23	9-1048-0007-1	6 A10,5 DIN 125 [—]
24	9-1048-0012-6	1 A13 DIN 125 [—]
25	9-1048-0041*0	1 A13 DIN 9021 [—]

REF.	ONDERDEELNR. PART NUMBER REFERENCE TEILNUMMER	AANTAL QUANTITY QUANTITE ANZAHL
------	--	--

26	9-1048-0063-1	1 41 DIN 1441 [—]
27	9-1048-0067-5	4 A13 DIN 9021 [—]
28	9-1051-0003-1	6 A12,5 DIN 6798 [####]
29	9-1068-0007*2	3 AM8x1,25
30	9-1070-0018-4	2 Ø6x40 DIN 1481
31	9-1070-0031-3	3 Ø12x60 DIN 1481
32	9-1070-0038-3	1 Ø10x75 DIN 1481
33	9-1070-0076-6	1 Ø7x50 DIN 1481
34	9-1083-0024-4	1
35	9-1105-0007-0	2 Ø7
36	9-1108-0020-3	1 Ø36x14
37	9-1108-0036-6	2 Ø10,7x5,5
38	9-1113-0013-5	4 M8x16 DIN 933-8.8
39	9-1113-0044-1	1 M10x120 DIN 931-8.8
40	9-1113-0049*6	2 M12x25 DIN 933-8.8
41	9-1113-0094*2	3 M20x90 DIN 931-8.8
42	9-1113-0115*2	2 M10x40 DIN 931-10.9
43	9-1113-0117*4	2 M10x35 DIN 933-8.8
44	9-1113-0118*5	1 M12x40 DIN 933-8.8
45	9-1113-0147*6	4 M12x30 DIN 933-10.9
46	9-1113-0360*1	1 M12x150 DIN 933-10.9
47	9-1121-0014-5	3 A20 DIN 127 [—]
48	9-1170-0205-0	1 "Smeerpunt" "Greasing point" "Point de graissage" "Schmierstelle"





SPLENDIMO	type number type number numéro de type Typnummer	vanaf serienummer as from serial number après numéro de série ab Seriennummer
280 LC	4.1253.0002.1 4.1253.0003.1 4.1253.0004.1	10807 - 0645 3001510 0000000

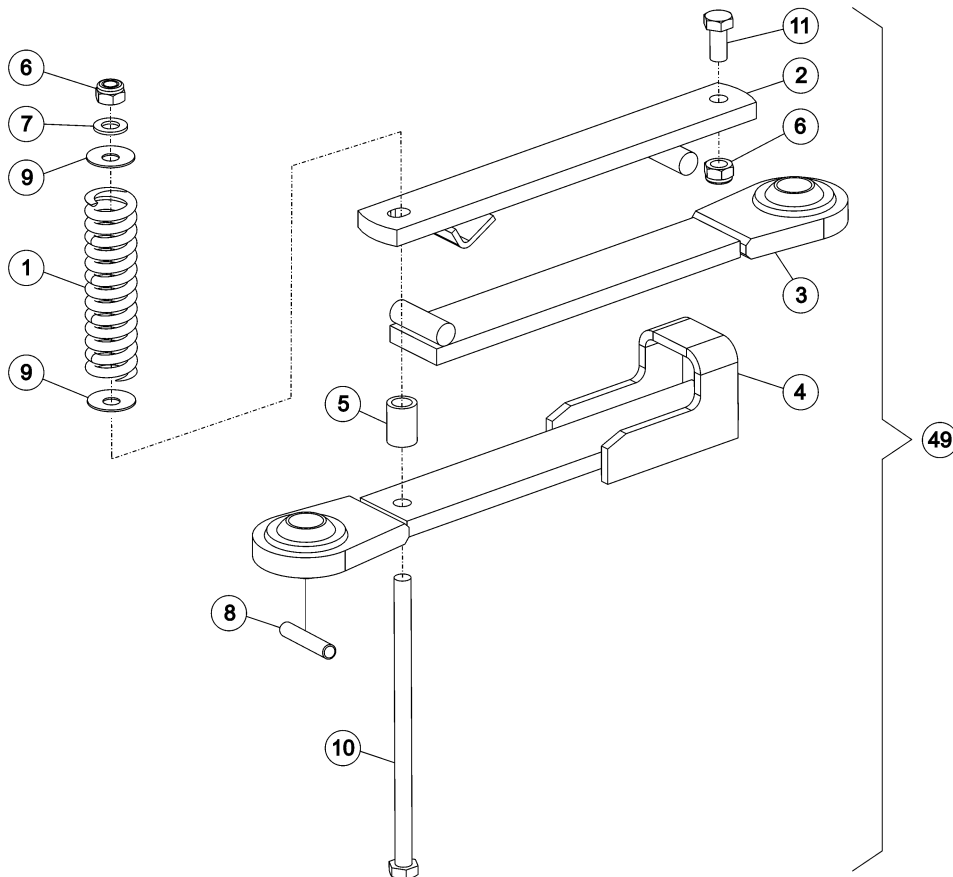
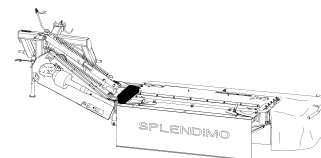

E212-02-00

REF.	ONDERDEELNR. PART NUMBER REFERENCE TEILNUMMER	AANTAL QUANTITY QUANTITE ANZAHL
------	--	--

1	4-1203-0219-0	1
2	4-1219-0111-0	1
3	4-1220-1380-0	1
4	4-1253-0350-0	1
5	4-1220-0809-0	1
6	9-1030-0015*6	2
7	9-1048-0053-5	1
8	9-1070-0028-0	2
9	9-1091-0008-1	2
10	9-1113-0161*6	1
11	9-1113-0119*6	1

M14 DIN985-8  
A15 DIN 125 [—]  
Ø10x60 DIN 1481  
40x14,3x1,5  
M14x260 DIN 931-8.8  
M14x30 DIN 933-10.9

REF.	ONDERDEELNR. PART NUMBER REFERENCE TEILNUMMER	AANTAL QUANTITY QUANTITE ANZAHL
------	--	--

49	4-1253-0330-0	1 = REF.(1-11)
----	---------------	----------------



SPLENDIMO	type nummer type number numéro de type Typnummer	vanaf serienummer as from serial number après numéro de serie ab Seriennummer
	280 LC	4.1253.0002.1 4.1253.0003.1
		10807 - 0645 3001510

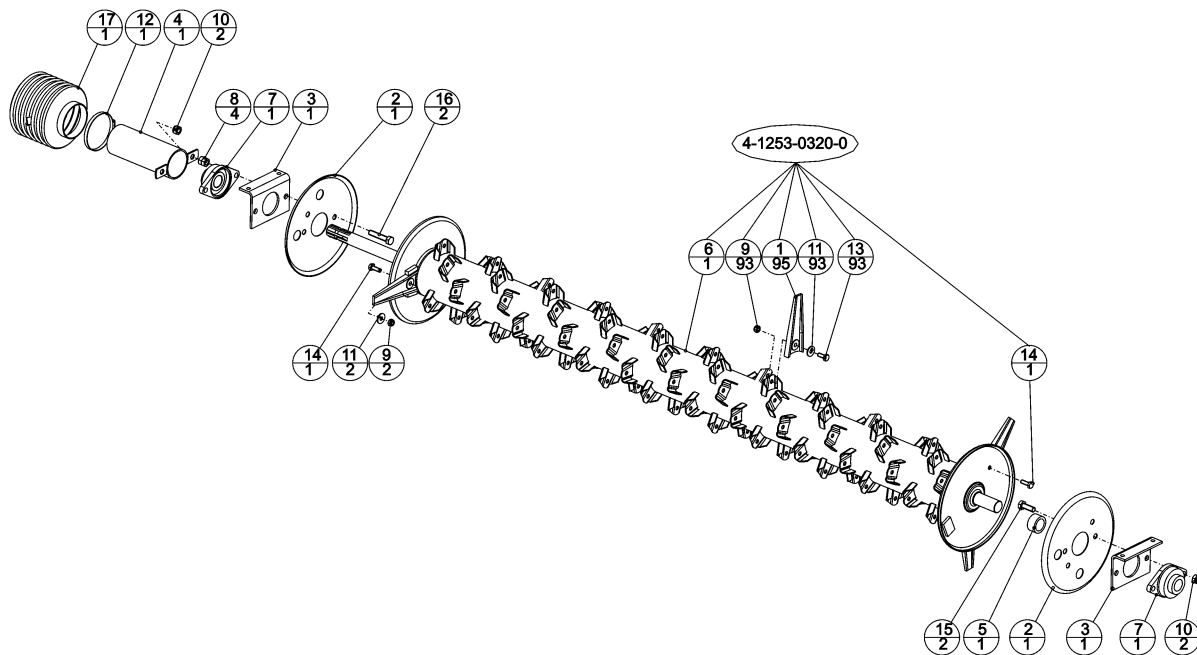
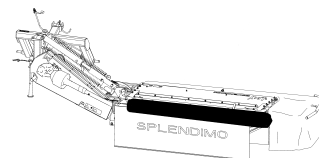

E213-03-00

REF.	ONDERDEELNR. PART NUMBER REFERENCE TEILNUMMER	AANTAL QUANTITY QUANTITE ANZAHL
------	--	--

1	4-1207-0228-0	95
2	4-1207-0229-0	2
3	4-1217-0120-0	2
4	4-1217-0270-0	1
5	4-1225-1481-0	1
6	4-1253-0370-0	1
7	9-1008-0018-3	2
8	9-1029-0012*4	4
9	9-1030-0004*2	95
10	9-1030-0015*6	4
11	9-1048-0008-2	95
12	9-1066-0006*3	1
13	9-1113-0029*0	93
14	9-1113-0120*0	2
15	9-1113-0142*1	2
16	9-1113-0247*1	2
17	9-1161-0009-2	1

REF.	ONDERDEELNR. PART NUMBER REFERENCE TEILNUMMER	AANTAL QUANTITY QUANTITE ANZAHL
------	--	--

49 4.1253.0320.0 1 = REF. 1+6+9+11+13+14

# LELY

SPLENDIMO	type nummer	vanaf serienummer
	type number	as from serial number
	numéro de type	après numéro de serie
	Typnummer	ab Seriennummer
280 LC	4.1253.0002.1 4.1253.0003.1 4.1253.0004.1	10807 - 0645 3001510 0000000

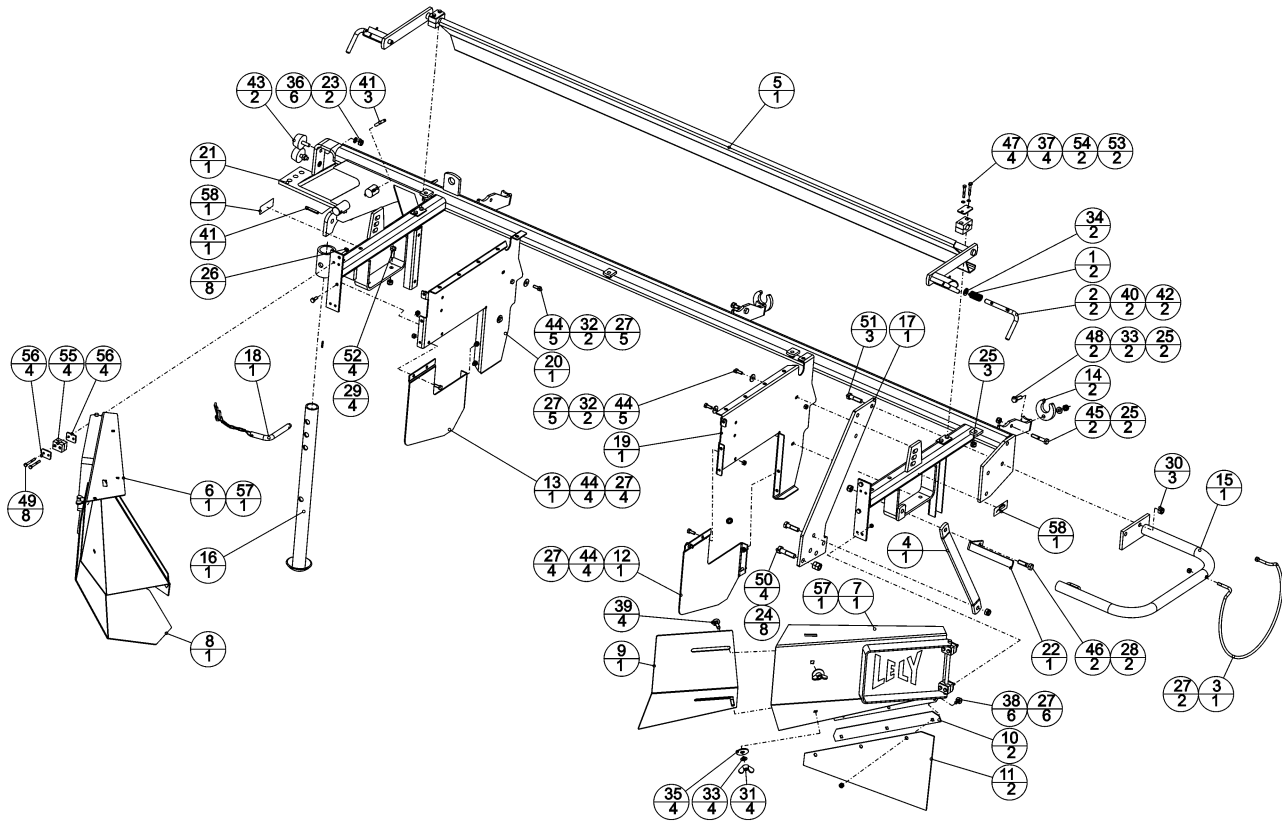
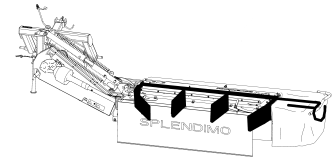

E214-03-00

REF.	ONDERDEELNR. PART NUMBER REFERENCE TEILNUMMER	AANTAL QUANTITY QUANTITE ANZAHL
------	--	--

1	4-1002-0093-0	2
2	4-1207-0188-0	2
3	4-1210-1496-0	1
4	4-1217-0127-0	1
5	4-1217-0400-0	1
6	4-1220-1881-0	1
7	4-1220-1891-0	1
8	4-1220-1908-0	1
9	4-1220-1909-0	1
10	4-1220-1967-0	2
11	4-1220-1987-0	2
12	4-1220-1997-0	1
13	4-1220-1998-0	1
14	4-1225-1486-0	2
15	4-1240-0351-0	1
16	4-1240-0510-0	1
17	4-1240-1492-0	1
18	4-1241-1020-0	1
19	4-1251-1498-0	1
20	4-1251-1499-0	1
21	4-1253-0310-0	1
22	4-1253-1497-0	1
23	9-1029-0005*4	2
24	9-1029-0012*4	8
25	9-1030-0004*2	7
26	9-1030-0011*2	8
27	9-1030-0012*3	26
28	9-1030-0013*4	2
29	9-1030-0018*2	4
30	9-1030-0024*1	3
31	9-1032-0003*6	4
32	9-1048-0005-6	4

REF.	ONDERDEELNR. PART NUMBER REFERENCE TEILNUMMER	AANTAL QUANTITY QUANTITE ANZAHL
------	--	--

33	9-1048-0007-1	6
34	9-1048-0012-6	2
35	9-1048-0067-5	4
36	9-1051-0002-0	6
37	9-1051-0006-4	4
38	9-1058-0008*6	6
39	9-1058-0015*6	4
40	9-1070-0017-3	2
41	9-1070-0023-2	4
42	9-1070-0049-0	2
43	9-1105-0011-4	2
44	9-1113-0014*6	18
45	9-1113-0036*0	2
46	9-1113-0054*4	2
47	9-1113-0106*0	4
48	9-1113-0117*4	2
49	9-1113-0181*5	8
50	9-1113-0246*0	4
51	9-1113-0252*6	3
52	9-1113-0276*2	4
53	9-1137-0904-4	2
54	9-1137-0905-5	2
55	9-1137-0914-0	4
56	9-1137-0915-1	8
57	9-1170-0001-6	2
58	9-1170-0205-0	2

A10,5 DIN 125	[ ]
A13 DIN 125	[ ]
A13 DIN 9021	[ ]
A10,5 DIN 6798	[####]
A6,4 DIN 6798	[####]
M8x20 DIN 603	[ ]
M10x35 DIN 603-8.8	[ ]
Ø6x30 DIN 1481	[ ]
Ø8x50 DIN 1481	[ ]
Ø6x24 DIN 1481	[ ]
K50x22,5-M10x28	[ ]
M8x20 DIN 933-8.8	[ ]
M10x55 DIN 931-8.8	[ ]
M12x45 DIN 931-8.8	[ ]
M6x40 DIN 931-8.8	[ ]
M10x35 DIN 933-8.8	[ ]
M6x50 DIN 931-8.8	[ ]
M14x55 DIN 931-8.8	[ ]
M12x45 DIN 931-10.9	[ ]
M10x30 DIN 933-10.9	[ ]
"LELY "	[ ]
"Smeerpunt"	[ ]
"Greasing point"	[ ]
"Point de graissage"	[ ]
"Schmierstelle"	[ ]

[ ]

# LELY

SPLENDIMO	type nummer type number numéro de type Typnummer	vanaf serienummer as from serial number après numéro de serie ab Serienummer
280 LC	4.1253.0002.1 4.1253.0003.1 4.1253.0004.1	10807 - 0645 3001510 0000000

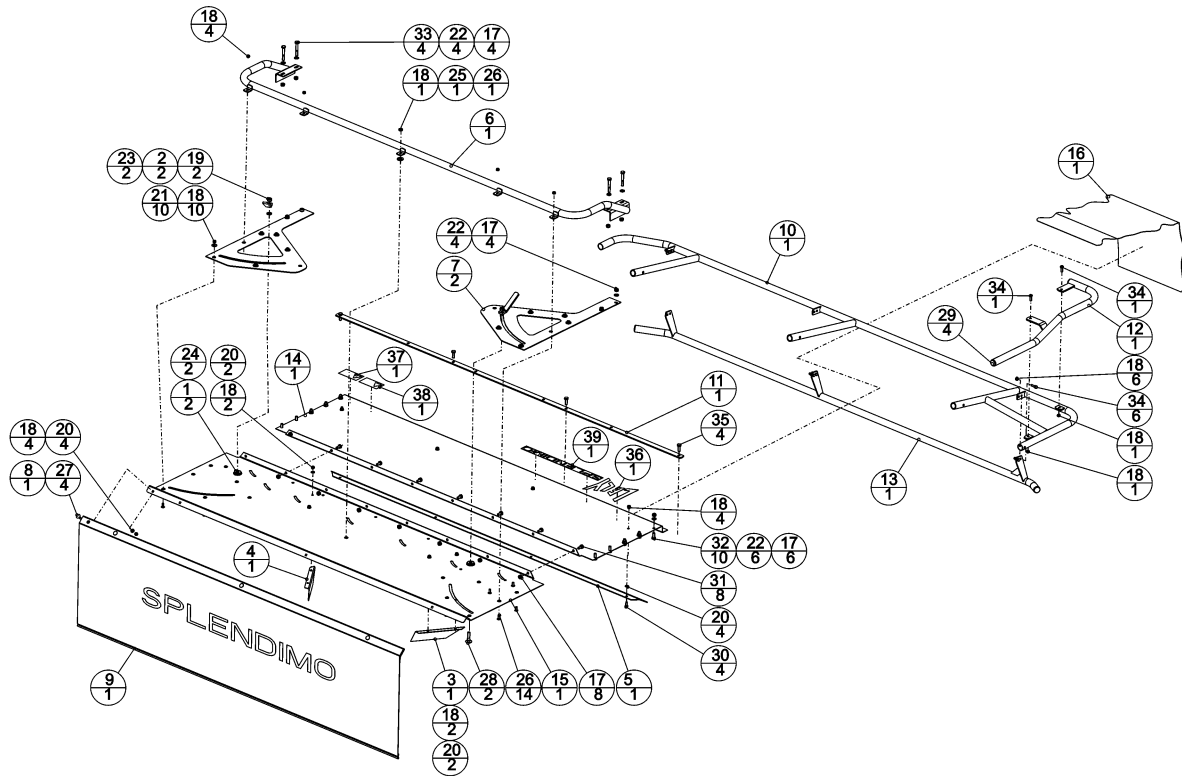
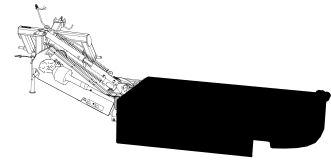

E215-03-00

REF.	ONDERDEELNR. PART NUMBER REFERENCE TEILNUMMER	AANTAL QUANTITY QUANTITE ANZAHL
------	--	--

1	1-1645-2673-0	2
2	4-1207-0184-0	2
3	4-1217-0361-0	1
4	4-1217-0362-0	1
5	4-1217-0364-0	1
6	4-1220-1450-0	1
7	4-1220-1452-0	2
8	4-1220-1454-0	1
9	4-1220-1905-0	1
10	4-1242-0411-0	1
11	4-1242-1485-0	1
12	4-1251-0410-0	1
13	4-1253-0430-0	1
14	4-1253-1488-0	1
15	4-1253-1489-0	1
16	4-1253-1490-0	1
17	9-1030-0004*2	22 M10 DIN 985-8
18	9-1030-0012*3	35 M8 DIN 985-8
19	9-1030-0013*4	2 M12 DIN 985-8
20	9-1048-0004-5	12 A8,4 DIN 125 [—]
21	9-1048-0005-6	10 A8,4 DIN 9021 [—]
22	9-1048-0007-1	14 A10,5 DIN 125 [—]
23	9-1048-0012-6	2 A13 DIN 125 [—]
24	9-1048-0067-5	2 A13 DIN 9021 [—]
25	9-1048-0085-2	1 A17 DIN 125-A2 [—]

REF.	ONDERDEELNR. PART NUMBER REFERENCE TEILNUMMER	AANTAL QUANTITY QUANTITE ANZAHL
------	--	--

26	9-1057-0320-4	15 M8x20 DIN 7991-A2-70
27	9-1058-0041*4	4 M8x25 DIN 603-8.8
28	9-1058-0042*5	2 M12x50 DIN 603-8.8
29	9-1108-0085-6	4 Ø32
30	9-1113-0014*6	4 M8x20 DIN 933-8.8
31	9-1113-0027*5	8 M10x20 DIN 933-8.8
32	9-1113-0029*0	10 M10x25 DIN 933-8.8
33	9-1113-0041*5	4 M10x70 DIN 931-8.8
34	9-1113-0128*1	8 M8x25 DIN 933-8.8
35	9-1113-0276*2	4 M10x30 DIN 933-10.9
36	9-1170-0113-6	1 "LELY"
37	9-1170-0407-6	1
38	9-1170-0408-0	1
39	9-1170-0449-6	1 "SPLENDIMO"



SPLENDIMO	type number type number numéro de type Typnummer	vanaf serienummer as from serial number après numéro de série ab Seriennummer
280 LC	4.1253.0002.1 4.1253.0003.1 4.1253.0004.1	10807 - 0645 3001510 0000000

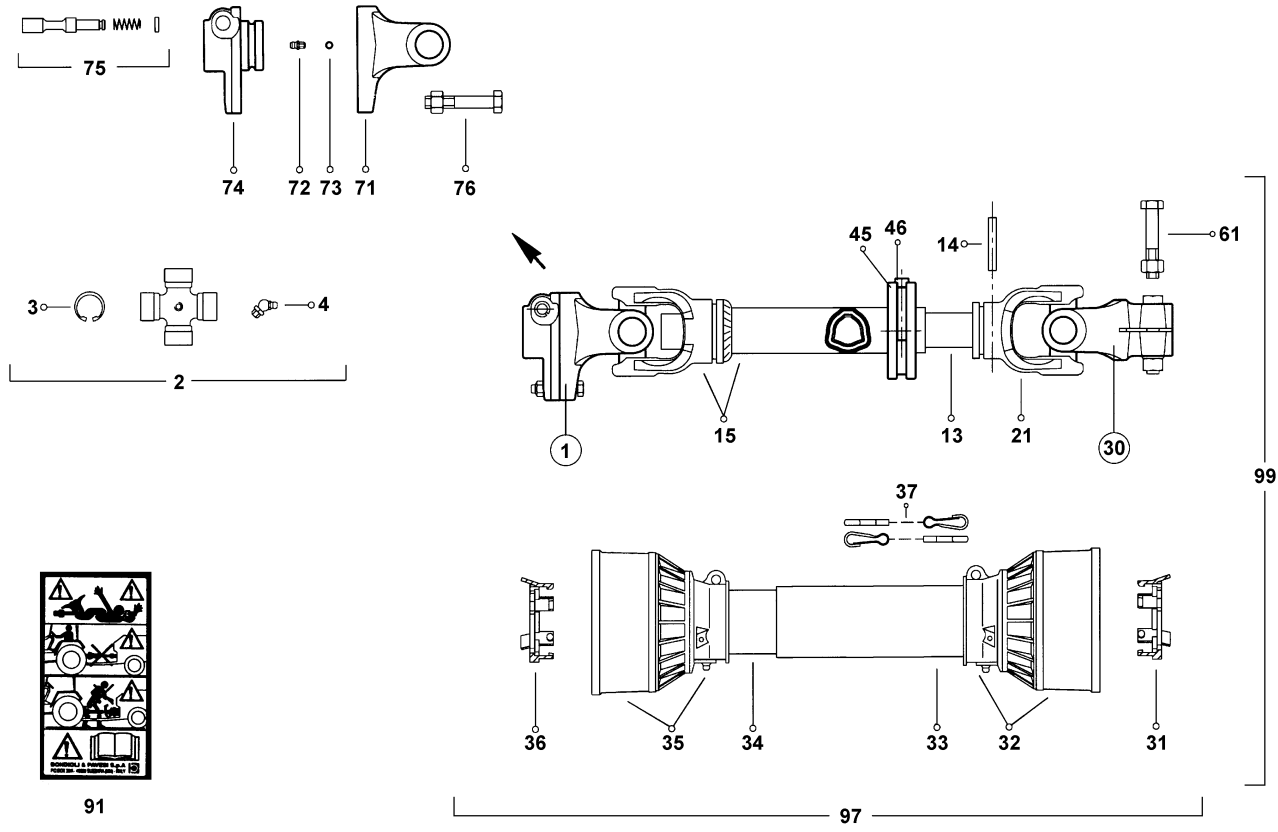
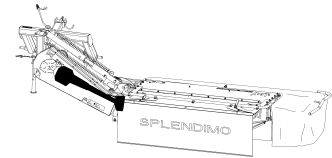

Eb002-02-01

REF.	ONDERDEELNR. PART NUMBER REFERENCE TEILNUMMER	AANTAL QUANTITY QUANTITE ANZAHL	
1	4.9000.0096.0	1	= REF. 71-76 1300 Nm SB3-M8
2	4.9000.0097.0	2	= REF. 2+3+4
3	4.9000.0073.0	8	
4	4.9000.0063.0	2	
13	4.9000.0098.0	1	L= 491 mm
14		1	Ø x
15	4.9000.0099.0	1	L= 430 mm
21	4.9000.0100.0	1	2 Serie 100
30	4.9000.0101.0	1	= REF. 30+61
31	4.9000.0007.0	1	
32	4.9000.0070.0	1	Type/Typ F
33	4.9000.0102.0	1	L= 391 mm
34	4.9000.0103.0	1	L= 377 mm
35	4.9000.0050.0	1	Type/Typ F
36	4.9000.0002.0	1	
37	4.9000.0003.0	2	
45	4.9000.0104.0	1	
46	4.9000.0105.0	1	

REF.	ONDERDEELNR. PART NUMBER REFERENCE TEILNUMMER	AANTAL QUANTITY QUANTITE ANZAHL	
61	9.1113.0059*2 9.1030.0013*4	1 1	M12x70 DIN 931-8.8 M12 DIN 985-8
71	4.9000.0106.0	1	
72	4.9000.0091.0	1	
73	4.9000.0092.0	24	7/32
74	4.9000.0107.0	1	1.3/8"SPL
75	4.9000.0094.0	1	Cpl.
76	9.1113.0019*4 9.1030.0012*3	1 1	M8x50 DIN 931-8.8 M8 DIN 985-8
91	4.9000.0075.0	1	
97	4.9000.0108.0	1	= REF. 31-37 Type/Typ F
99	9.1154.0207.4	1	= REF. 1-97 Type/Typ 3 L= 560 mm



SPLENDIMO	type number type number numéro de type Typnummer	vanaf serienummer as from serial number après numéro de serie ab Serienummer
	280 LC	4.1253.0002.1 4.1253.0003.1 4.1253.0004.1
		10807 - 0645 3001510 0000000

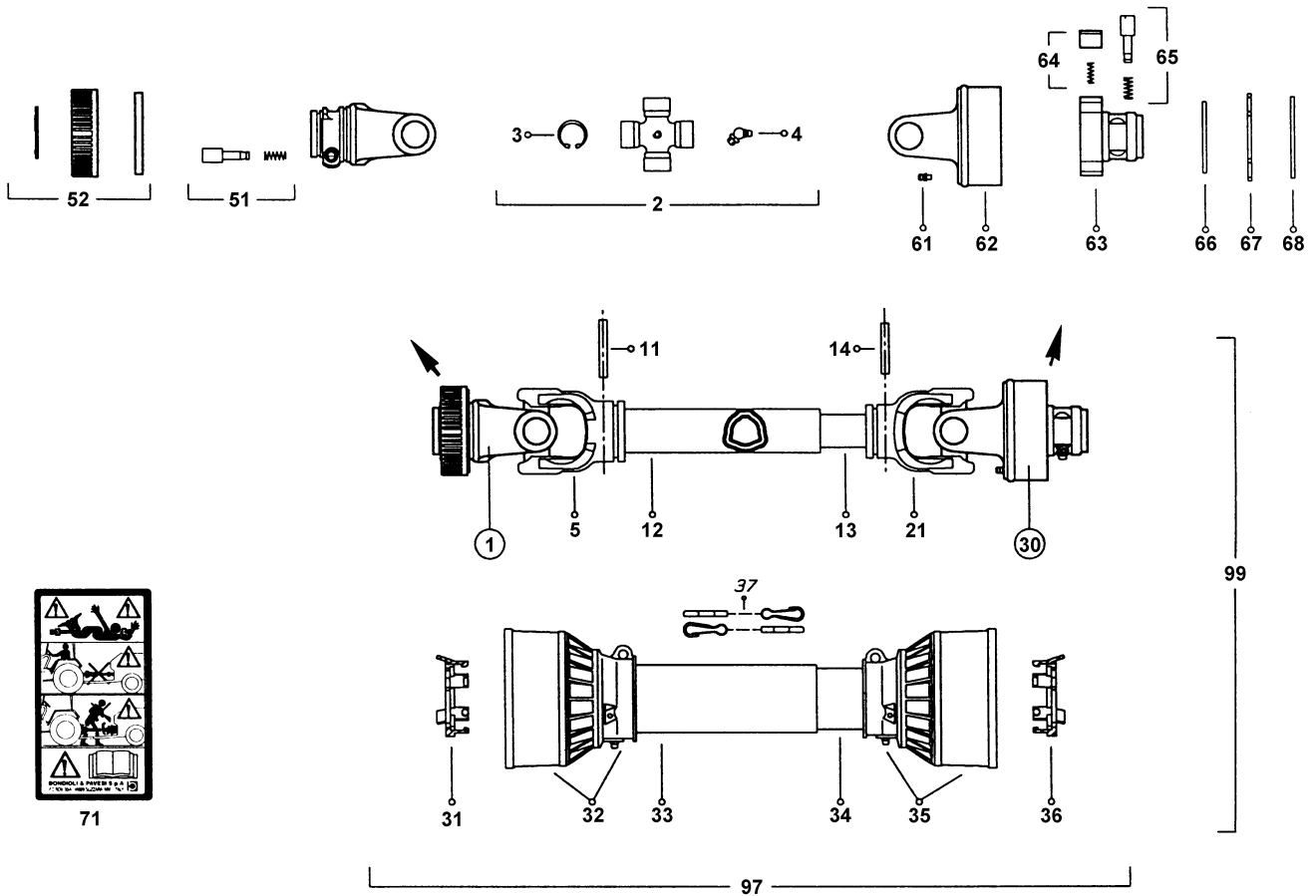
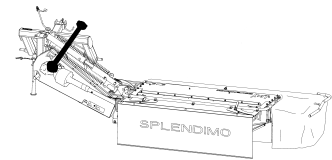

Eb001-01-01

REF.	ONDERDEELNR. PART NUMBER REFERENCE TEILNUMMER	AANTAL QUANTITY QUANTITE ANZAHL	
1	4.9000.0057.0	1	= REF. 1+51+52 1.3/8" (6)
2	4.9000.0061.0	2	= REF. 2+3+4
3	4.9000.0062.0	8	
4	4.9000.0064.0	2	
5	4.9000.0018.0	1	5 Serie 100
11	9.1070.0024.3	1	Ø8x60
12	4.9000.0022.0	1	L= 710 mm
13	4.9000.0024.0	1	L= 710 mm (Rilsan)
14	4.9000.0043.0	1	Ø10x61
21	4.9000.0020.0	1	5 Serie 100
30	4.9000.0045.0	1	= REF. 61-68 1600 Nm RA1/5-1.3/8"Z6
31	4.9000.0005.0	1	
32	4.9000.0046.0	1	Type/Typ F
33	4.9000.0025.0	1	L= 650 mm
34	4.9000.0027.0	1	L= 650 mm
35	4.9000.0047.0	1	Type/Typ F
36	4.9000.0000.0	1	
37	4.9000.0003.0	2	
51	4.9000.0051.0	1	
52	4.9000.0083.0	1	

REF.	ONDERDEELNR. PART NUMBER REFERENCE TEILNUMMER	AANTAL QUANTITY QUANTITE ANZAHL	
61	4.9000.0052.0	1	
62	4.9000.0032.0	1	
63	4.9000.0054.0	1	1.3/8"SPL
64	4.9000.0055.0	3	
65	4.9000.0051.0	1	
66	4.9000.0016.0	1	
67	4.9000.0017.0	1	
68	4.9000.0065.0	1	
71	4.9000.0075.0	1	
97	4.9000.0056.0	1	= REF. 31-37 Type/Typ F
99	9.1154.0188.6	1	= REF. 1-97 Type/Typ 1R5 L= 860 mm