

LELY

HIGH - TECH
IN AGRICULTURE

ONDERDELENLIJST
PARTS LIST
LISTE DE PIECES DE RECHANGE
ERSATZTEILLISTE

LOTUS 300 COMBI

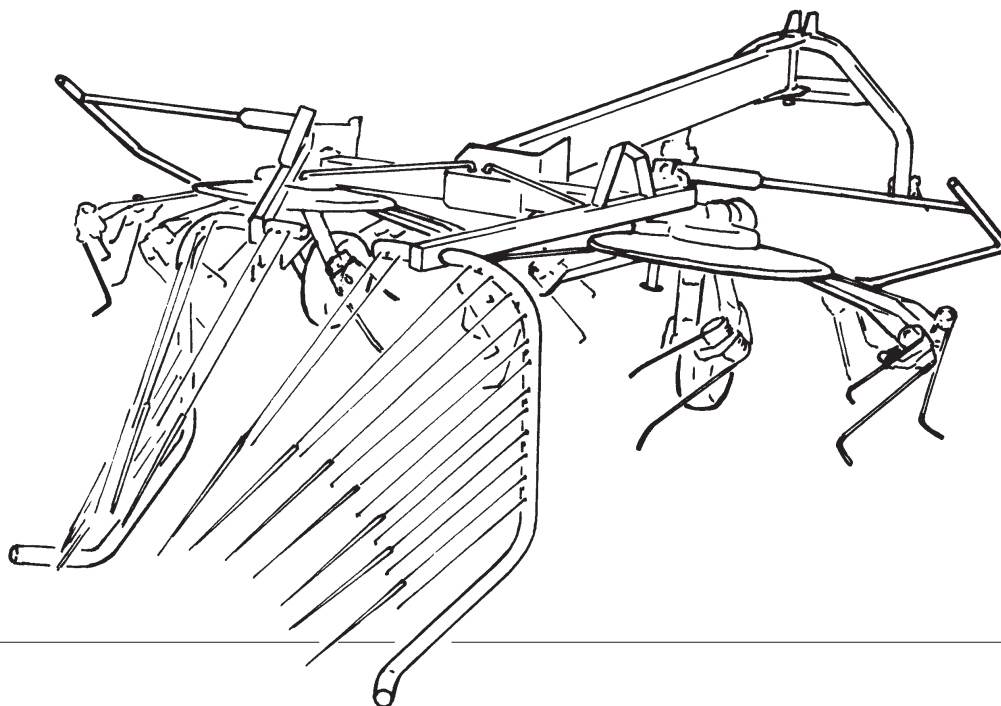

LOTUS	type number type number numéro de type Typennummer	vanaf serienummer as from serial number après numéro série ab Seriennummer
300 COMBI	4.1015.0000.3	10312 - 1151
300 COMBI	4.1015.0001.1	10312 - 0726



ONDERDELEN

Bij het bestellen van onderdelen is het belangrijk dat u het type- en serienummer van uw machine opgeeft.

Gebruik alleen originele LELY-onderdelen.

SPARE PARTS

When ordering spare parts, it is important that you indicate the type and serial number of your machine.

Use only genuine LELY parts.

PIECES DE RECHANGE

En commandant des pièces de rechange il importe que vous indiquiez les numéros de type et de série de votre machine.

N'utiliser que des pièces d'origines LELY.

ERSATZTEILE

Beim Bestellen von Ersatzteilen ist es wichtig, daß Sie die Typ- und Seriennummer Ihrer Maschine angeben.

Nur Original-LELY-Ersatzteile verwenden.

Typ- und Seriennummer in nebenstehende Abbildung eintragen. Bei künftigen Bestellungen haben Sie die Nummer dann griffbereit.

Vul het type- en serienummer hieronder in.

Bij toekomstige onderdelenbestellingen heeft u de nummers dan bij de hand.

Complete the box below with the type and serial number.

This is an easy reference with a view to future spare parts ordering.

Veillez noter, ci-dessous, les numéros de type et de serie.

Ceci est important pour toutes commandes de pièces de rechange.

LELY	LELY INDUSTRIES NV		CE
	3147 PA MAASSLUIS THE NETHERLANDS		
		kg	
Type			
Ser.Nr.			

Verklaring van de in de onderdelenlijst gebruikte tekens.

Explanation of signs used in the parts list.

Explication des signes qui figurent dans la liste des pièces.

Erklärung der in der Ersatzteilliste verwendeten Zeichen.

[R] = RECHTSE UITVOERING
RH VERSION

[L] = LINKSE UITVOERING
LH VERSION

Onder rechtse of linkse uitvoering wordt de plaats van het onderdeel verstaan, gezien van de achterzijde van de machine.

By RH or LH version the position of the part is meant, seen from the rear of the machine

[RD] = RECHTSOM DRAAIENDE UITVOERING
RH ROTATING VERSION

[LD] = LINKSOM DRAAIENDE UITVOERING
LH ROTATING VERSION

Onder rechtsom of linksom draaiende uitvoering wordt de draairichting van het onderdeel verstaan, gezien van de bovenzijde van de machine.

By RH or LH rotating version the sense of rotating of the part is meant, seen from the top of the machine.

[x] = ONDERDEEL WORDT NIET GETOOND
PART IS NOT SHOWN

Bijvoorbeeld linkse uitvoering overeenkomstig de wel getekende rechtse uitvoering.

E.g. : LH version is similar to the RH version, which is actually shown.

[#] = NIET LOS LEVERBAAR
NOT AVAILABLE SEPARATELY

~ = AANTAL (INDIEN NODIG) AFHANKELIJK VAN INBOUWMAAT
QUANTITY (IF APPLICABLE) DEPENDING UPON ASSEMBLY

[—] = SLUITRING

[—/—] = VEERRING

[###] = TANDVEERRING

[»|«] = OLIEKEERRING

[T+T] = TANDWIELSET

[D+D] = VULRINGSET

[A+A] = SET AFDICHTINGSRINGEN

WASHER

SPRING WASHER

SHAKE-PROOF WASHER

OIL SEAL

PAIR OF GEARS

SHIM SET

SET OF SEALING RINGS

VERSION DROITE
RECHTE AUSFÜHRUNG

VERSION GAUCHE
LINKE AUSFÜHRUNG

Par version droite ou gauche on entend la position de la pièce, vue de l'arrière de la machine.

Die Verweisungen "rechte Ausführung" oder "linke Ausführung" geben die Position des Teils, von der Hinterseite der Maschine aus gesehen, an.

VERSION ROTATION A DROITE
RECHTSUMDREHENDE AUSFÜHRUNG

VERSION ROTATION A GAUCHE
LINKSUMDREHENDE AUSFÜHRUNG

Version rotation à droit: ceci correspond au sens de rotation de la pièce, vue du dessus la machine.

Mit diesen Verweisungen wird die Drehrichtung des Teils von der Oberseite der Maschine aus gesehen, angegeben.

PIECE N'EST PAS MONTREE
TEIL WIRD NICHT GEZEIGT

Exemple : la version gauche est représentée. La version droite correspond à la version gauche, mais n'est pas représentée.

Beispiel : die linke Ausführung entspricht der effektiv gezeigten Rechten.

VENDU EN KIT UNIQUEMENT
NICHT SEPARAT LIEFERBAR

QUANTITE (SI NÉCESSAIRE) EN FONCTION DU MONTAGE
ANZAHL VOM EINBAUMASS ABHÄNGIG (WENN ERFORDERLICH)

RONDELLE PLATE

RONDELLE GROWER

RONDELLE EVENTAIL

ETANCHEITE

JEU D'ENGRENAGES

JEU D'ÉPAISSEURS

JEU D'ANNEAUX D'ETANCHEITE

UNTERLEGSCHEIBE

FEDERRING

RÄNDELFEDERRING

ÖLDICHTUNGSRING

ZAHNRÄDERSATZ

PASSSCHEIBENSATZ

DICHTUNGSRINGENSATZ

LOTUS 300 COMBI

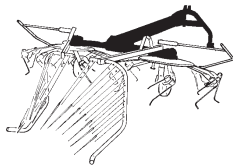

Driepuntsbok + frame
Headstock + frame
Tête d'attelage + châssis
Driepunktturm + Rahmen

01

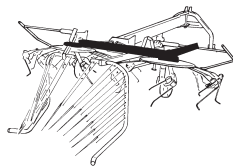

Aandrijving
Transmission
Entraînement
Antrieb

02

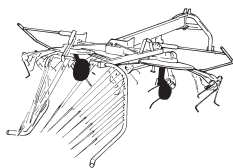

Loopwielen
Support wheels
Roues de support
Stützräder

02

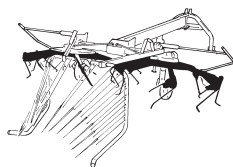

Rotoren
Rotors
Rotors
Rotoren

03

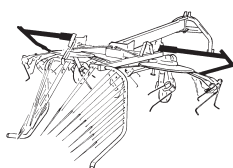

Beschermbeugels
Protection brackets
Arceaux projecteurs
Schutzbügel

03

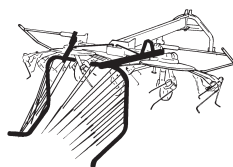

Wiersborden
Deflectors
Planches à andain
Schwadbretter

04

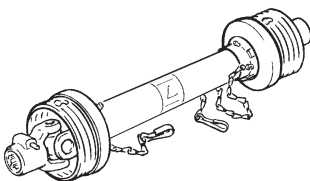

Koppelingsas
PTO shaft
Arbre de transmission
Gelenkwelle

05/06

LELY

LOTUS	type number type number numéro de type Typnummer	vanaf serienummer as from serial number après numéro de serie ab Seriennummer
300 COMBI	4.1015.0000.3	1002 - 0501
300 COMBI	4.1015.0001.1	1015 - 0501

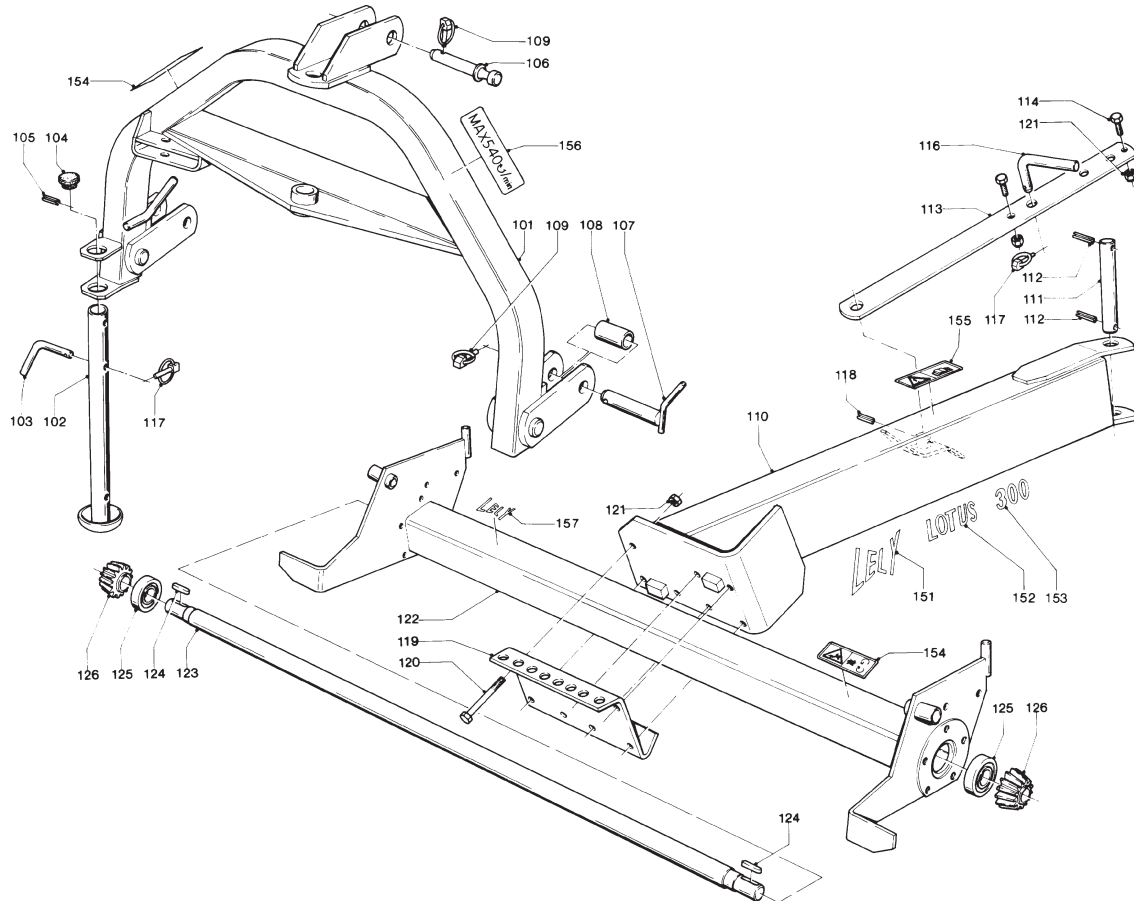
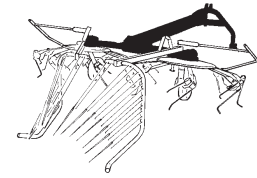

B001.05.00

REF.	ONDERDEELNR. PART NUMBER REFERENCE TEILNUMMER	AANTAL QUANTITY QUANTITE ANZAHL
------	--	--

101	4.1015.0170.0	1
102	4.1017.0141.0	1
103	4.1003.0018.0	1
104	9.1108.0021.4	1
105	9.1070.0023.2	1
	Ø26,2	
	Ø8x50 DIN 1481	
106	9.1088.0005.1	1
	25-95	
107	2.3215.0100.0	2
108	9.1097.0001*2	2
109	9.1123.0002*5	3
	Ø11	
110	4.1015.0150.0	1
111	4.1015.1495.0	1
112	9.1070.0039.4	2
	Ø10x50 DIN 1481	
113	4.1015.1499.0	1
114	9.1113.0049*6	2
	M12x25 DIN 933-8.8	
116	4.1011.0033.0	1
117	9.1123.0003*6	2
	Ø6	
118	9.1070.0017.3	1
	Ø6x30 DIN 1481	
119	4.1015.1497.0	1
120	9.1113.0066*2	6
	M12x110 DIN 931-8.8	
121	9.1030.0013*4	8
	M12 DIN 985-8	
122	4.1015.0100.0	1
123	4.1011.0011.0	1
124	9.1071.0011.3	2
	A8x7x40 DIN 6885	
125	9.1001.0137.3	2
	6306-2RS1-C3	
126	4.1003.0159.0	2

REF.	ONDERDEELNR. PART NUMBER REFERENCE TEILNUMMER	AANTAL QUANTITY QUANTITE ANZAHL
------	--	--

151	9.1170.0003.1	2
	"LELY"	
152	9.1170.0377.4	2
	"LOTUS"	
153	9.1170.0376.3	2
	"300"	
154	9.1170.0407.6	2
155	9.1170.0408.0	1
156	9.1170.0125.4	1
	"MAX 540/min."	
157	9.1170.0200.2	1
	"LELY"	

LELY

LOTUS	type nummer type number numéro de type Typnummer	vanaf serienummer as from serial number après numéro de serie ab Seriennummer
300 COMBI	4.1015.0000.3	10312 - 1151
300 COMBI	4.1015.0001.1	10312 - 072

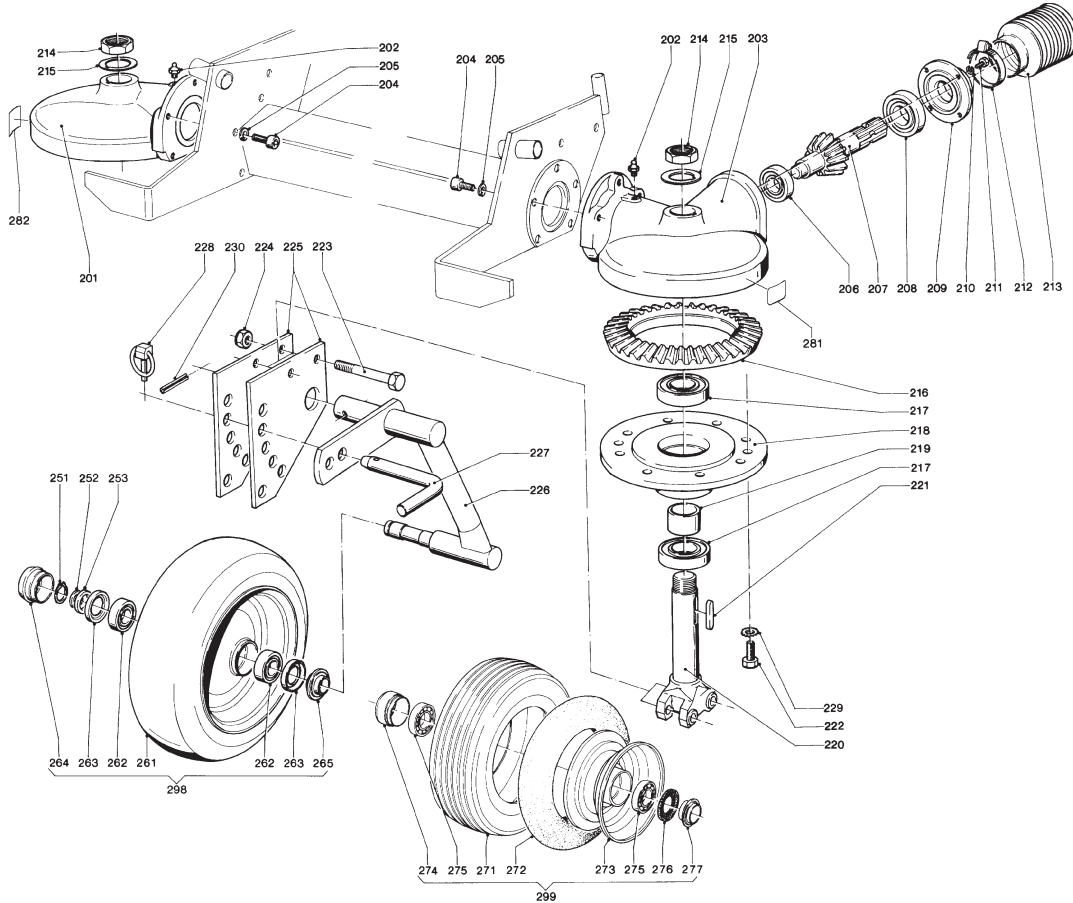
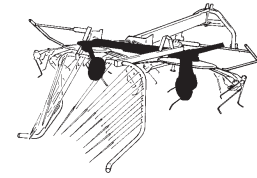

B002.05.01

REF.	ONDERDEELNR. PART NUMBER REFERENCE TEILNUMMER	AANTAL QUANTITY QUANTITE ANZAHL	
------	--	--	--

201	4.1011.1998.0	1	
202	9.1068.0007*2	2	AM8x1,25 DIN 71412
203	4.1011.1999.0	1	
204	9.1057.0023.1	10	M12x30 DIN 912-12.9
205	9.1121.0023.0	10	12 DIN 7980 [/ /]
206	9.1001.0100.1	1	6205-2Z
207	4.1003.0158.0	1	
208	9.1001.0025.3	1	6207-2RS1
209	4.1003.0160.0	1	
210	9.1051.0001.6	4	A8,4 DIN 6798 [/ / / /]
211	9.1113.0014*6	4	M8x20 DIN 933-8.8
212	9.1066.0002*6	1	Ø60-82
213	4.1015.0038.0	1	
214	9.1036.0004.3	2	G1"
215	4.1011.0034.0	2	
216	4.1015.0149.0	2	
217	9.1001.0099.0	4	6208-2Z
218	4.1016.0809.0	2	
219	4.1003.0163.0	2	
220	4.1015.0147.0	2	
221	9.1071.0025.3	2	A12x8x50 DIN 6885
222	9.1113.0049*6	4	M12x25 DIN 933-8.8
223	9.1113.0151*3	4	M14x100 DIN 931-8.8
224	9.1030.0015*6	4	M14 DIN 985-8
225	4.1015.0146.0	4	
226	4.1016.2290.0	1	[R]
	4.1016.2280.0	1	[L][x]
227	4.1015.0145.0	2	
228	9.1123.0004*0	2	Ø8
229	9.1051.0003.1	4	A12,5 DIN 6798 [/ / / /]
230	9.1070.0039.4	2	Ø10x50 DIN 1481

REF.	ONDERDEELNR. PART NUMBER REFERENCE TEILNUMMER	AANTAL QUANTITY QUANTITE ANZAHL	
------	--	--	--

251	9.1119.0022.1	2	25x2-06 DIN 471
252	9.1052.0007*4	2	25x35x2 DIN 988 [—]
253	4.1011.0066.0	2	
261	[#]	1+1	b= 100 mm
262	9.1001.0126.6	2+2	6205-2RS1-C3
263	9.1106.0014.6	2+2	
264	9.1041.0100.3	1+1	Ø52 mm
265	9.1106.0015.0	1+1	
271	9.1110.0023.4	1+1	16x6.9-8 6 ply
272	9.1111.0017.4	1+1	16x6.50-8
273	9.1102.0024.6	1+1	5,50 x 8
274	9.1041.0104.0	1+1	Ø52x32
275	9.1001.0081.3	2+2	6205-2RS1
276	9.1106.0014.6	1+1	
277	9.1106.0015.0	1+1	
281	9.1170.0089.3	1	[R] Blauw/Blue/Bleu/blau
282	9.1170.0017.1	1	[L] Geel/Yellow/Jaune/Gelb
298	4.1015.0070.0	2	= REF. 261-265 b= 100 mm massief, solid, pneus pleins, Vollgummi
299	4.1033.0920.0	2	= REF. 271-277 lucht, pneumatic, pneumatiques, Luft

LELY

LOTUS	type number type number numéro de type Typnummer	vanaf serienummer as from serial number après numéro de serie ab Seriennummer
300 COMBI	4.1015.0000.3	10312 - 1151
300 COMBI	4.1015.0001.1	10312 - 0726

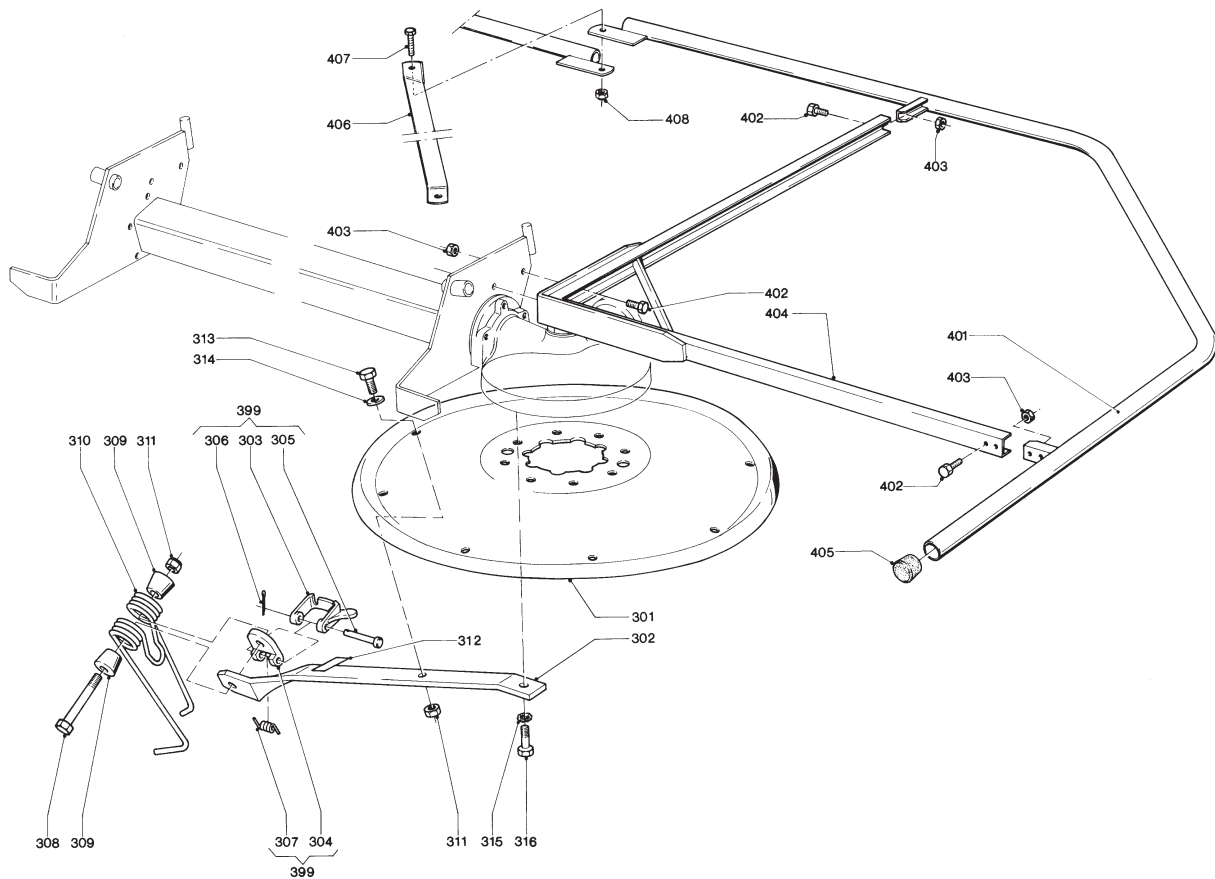
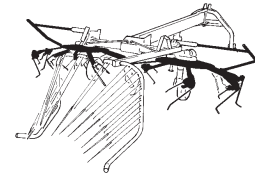

B003.04.01

REF.	ONDERDEELNR. PART NUMBER REFERENCE TEILNUMMER	AANTAL QUANTITY QUANTITE ANZAHL
------	--	--

301	4.1015.0143.0	2
302	4.1016.0158.0	8
	4.1016.0148.0	8
303	4.1015.0057.0	16
304	4.1015.0056.0	16
305	9.1115.0101.0	16
306	9.1072.0001*6	16
307	4.1015.0054.0	16
308	9.1113.0136*2	16
309	4.1015.0055.0	32
310	4.1016.0159.0	8
	4.1016.0149.0	8
311	9.1030.0013*4	32
312	9.1170.0085.6	8
	9.1170.0084.5	8
313	9.1113.0050*0	16
314	9.1048.0041*0	16
315	9.1051.0003.1	16
316	9.1113.0125*5	16

REF.	ONDERDEELNR. PART NUMBER REFERENCE TEILNUMMER	AANTAL QUANTITY QUANTITE ANZAHL
------	--	--

401	4.1015.2040.0	2
402	9.1113.0125*5	12
403	9.1030.0013*4	12
404	4.1015.2060.0	2
405	9.1108.0023.6	4
406	4.1015.1494.0	1
407	9.1113.0120*0	2
408	9.1030.0004*2	2
399	4.1016.0151.2	(8)
	4.1016.0141.2	(8)

M12x35 DIN 933-8.8
M12 DIN 985-8M10x30 DIN 933-8.8
M10 DIN 985-8= REF. 303-307 [R][LD]
= REF. 303-307 [L][RD][x][]
[#####]

LELY

LOTUS	type number type number numéro de type Typnummer	vanaf serienummer as from serial number après numéro de serie ab Seriennummer
300 COMBI	4.1015.0000.3	920 - 0501
300 COMBI	4.1015.0001.1	1015 - 0501

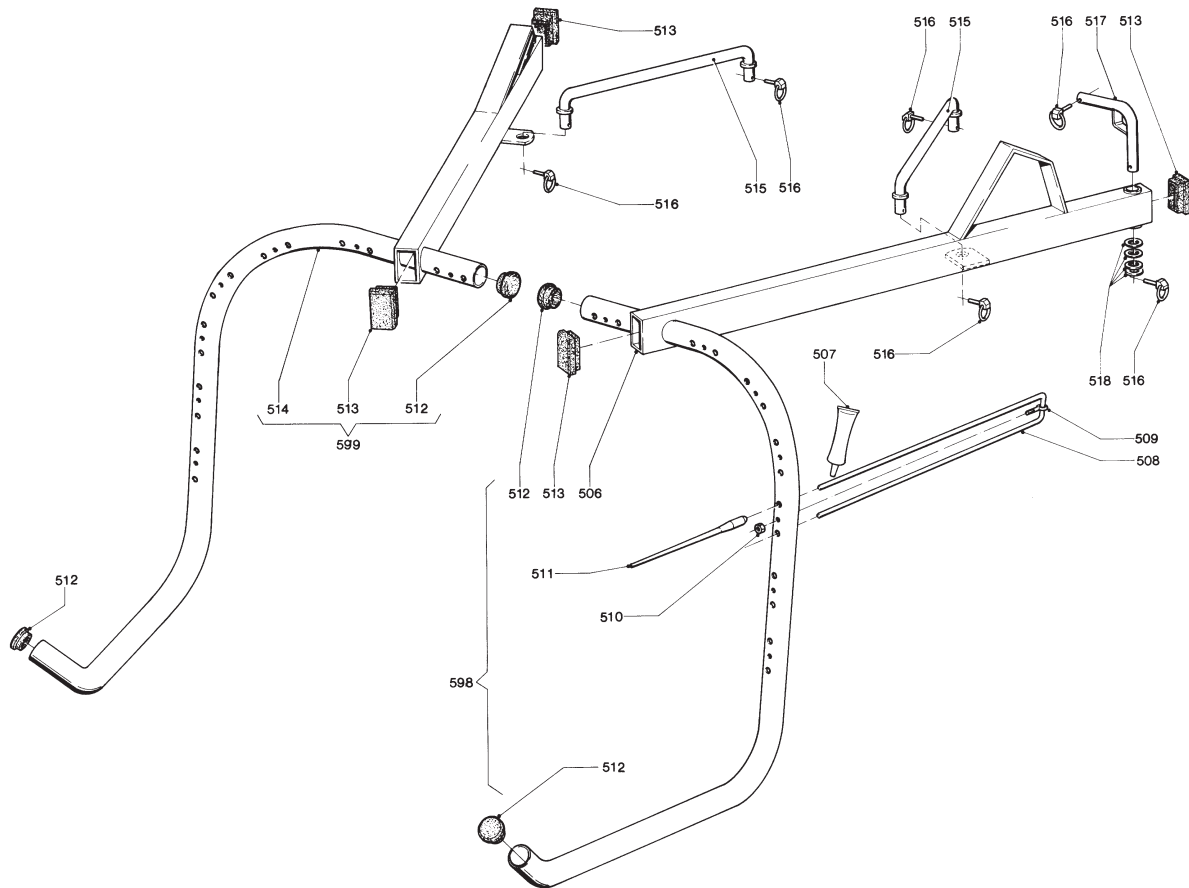
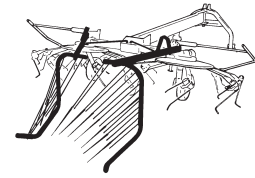

B004.04.00

REF.	ONDERDEELNR. PART NUMBER REFERENCE TEILNUMMER	AANTAL QUANTITY QUANTITE ANZAHL
------	--	--

[R] [L]

506	4.1015.0240.0	1	[R]
507	9.1126.0003.3	~	Permabond A118 10ml.
508	4.1015.0215.0	7+7	
509	4.1011.0009.0	7+7	
510	9.1030.0001*6	7+7	M6 DIN 985-6
511	4.1002.0163.0	7+7	
512	9.1108.0020.3	2+2	
513	9.1108.0026.2	2+2	
514	4.1015.0220.0	1	[L]
515	4.1015.0200.0	2	
516	9.1123.0003*6	8	Ø6
517	4.1015.0191.0	2	
518	9.1048.0019*6	8	A21 DIN 125 [—]

REF.	ONDERDEELNR. PART NUMBER REFERENCE TEILNUMMER	AANTAL QUANTITY QUANTITE ANZAHL
------	--	--

598	4.1015.0230.0	1	= REF. 506-513 [R]
599	4.1015.0210.0	1	= REF. 507-514 [L]

LELY

LOTUS	type number type number numéro de type Typnummer	vanaf serienummer as from serial number après numéro de serie ab Seriennummer
300 COMBI	4.1015.0000.3	920 - 0501
300 COMBI	4.1015.0001.1	1015 - 0501

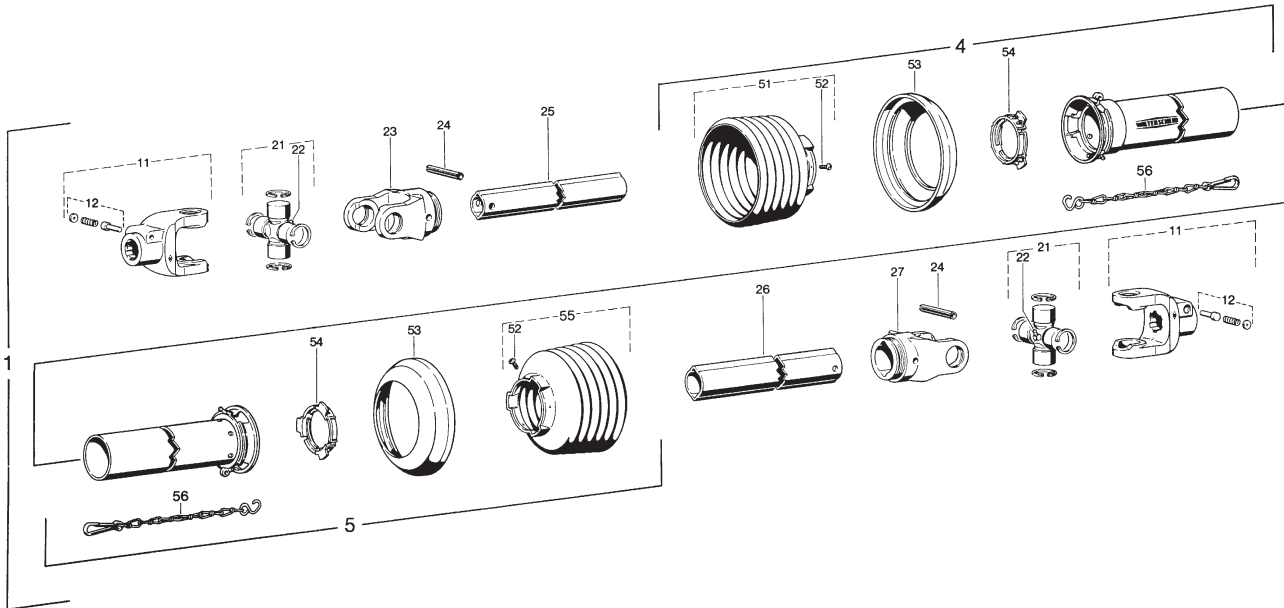
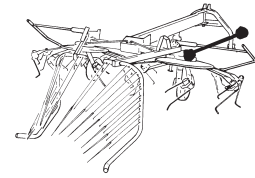

Bw003.04.00

REF.	ONDERDEELNR. PART NUMBER REFERENCE TEILNUMMER	AANTAL QUANTITY QUANTITE ANZAHL	
------	--	--	--

1	9.1154.0091.0	1	W2200-SD15-1010 mm = REF. 11-56
4	85.105	1	SDH15; 840 mm
5	85.104	1	SDH15; 840 mm
11	20.10.00	2	1.3/8" (6)
12	33.91.07	2	AGRASET 101
21	20.00.00	2	
22	63.27.00	2	BM 8x1
23	20.11.00	1	RG 2200-Ov
24	61.05.04	2	Ø10x65 DIN 1481
25	75.11.16	1	Ov; L= 900 mm
26	75.15.16	1	1; L= 895 mm
27	20.12.00	1	RG 2200-1
51	85.15.04	1	n= 4
52	60.15.00	2	4x10
53	82.85.00	2	
54	82.83.06	2	
55	85.15.05	1	n= 5
56	82.36.03	2	

REF.	ONDERDEELNR. PART NUMBER REFERENCE TEILNUMMER	AANTAL QUANTITY QUANTITE ANZAHL	
------	--	--	--

LELY

LOTUS	type number type number numéro de type Typnummer	vanaf serienummer as from serial number après numéro de serie ab Seriennummer
300 COMBI	4.1015.0000.3	920 - 0501
300 COMBI	4.1015.0001.1	1015 - 0501

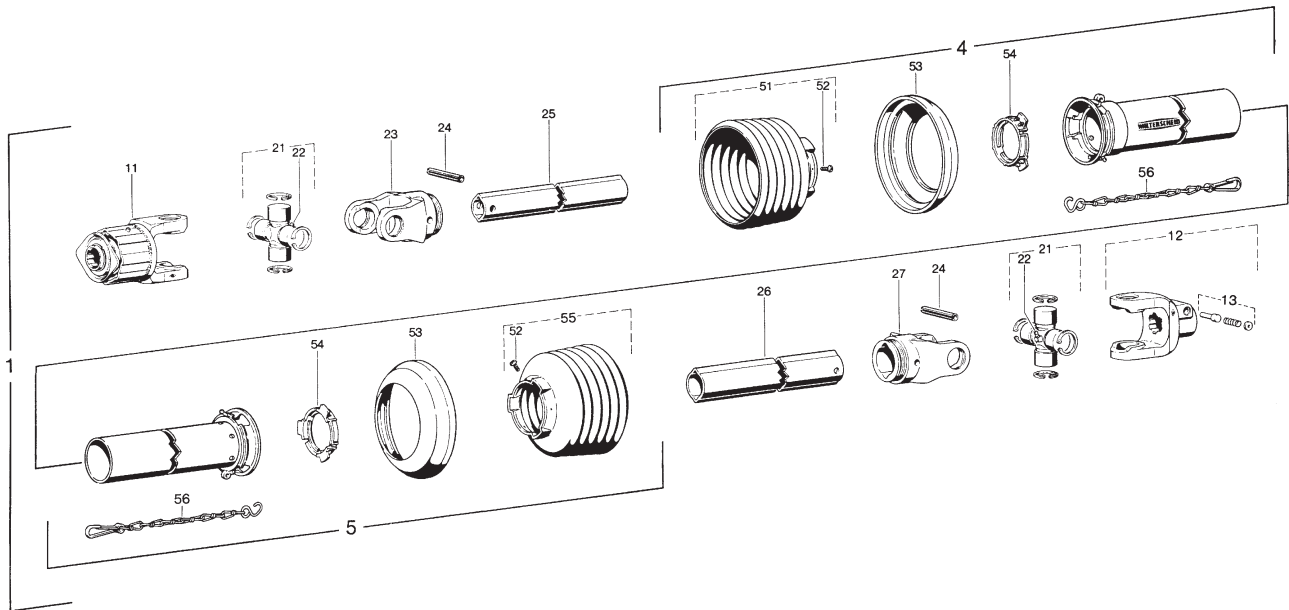
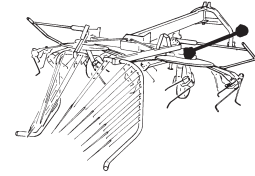

Bw006.03.00

REF.	ONDERDEELNR. PART NUMBER REFERENCE TEILNUMMER	AANTAL QUANTITY QUANTITE ANZAHL	
------	--	--	--

1	9.1154.0057.1	(1)	W2200-SD15-1010 mm = REF. 11-56
4	85.105	1	SDH15; L= 840 mm
5	85.104	1	SDH15; L= 840 mm
11	55.198.03	1	K33 B-1.3/8" (6) M= 650Nm
12	20.10.00	1	1.3/8" (6)
13	33.91.07	1	AGRASET 101
21	20.00.00	2	
22	63.27.00	2	BM 8x1
23	20.11.00	1	RG 2200-0v
24	61.05.04	2	Ø10x65 DIN 1481
25	75.11.16	1	0v; L= 900 mm
26	75.15.16	1	1; L= 895 mm
27	20.12.00	1	RG 2200-1
51	85.15.07	1	n= 7
52	60.15.00	2	4x10
53	82.85.00	2	
54	82.83.06	2	
55	85.15.04	1	n= 4
56	82.36.03	2	

REF.	ONDERDEELNR. PART NUMBER REFERENCE TEILNUMMER	AANTAL QUANTITY QUANTITE ANZAHL	
------	--	--	--